

96-1 Police Option

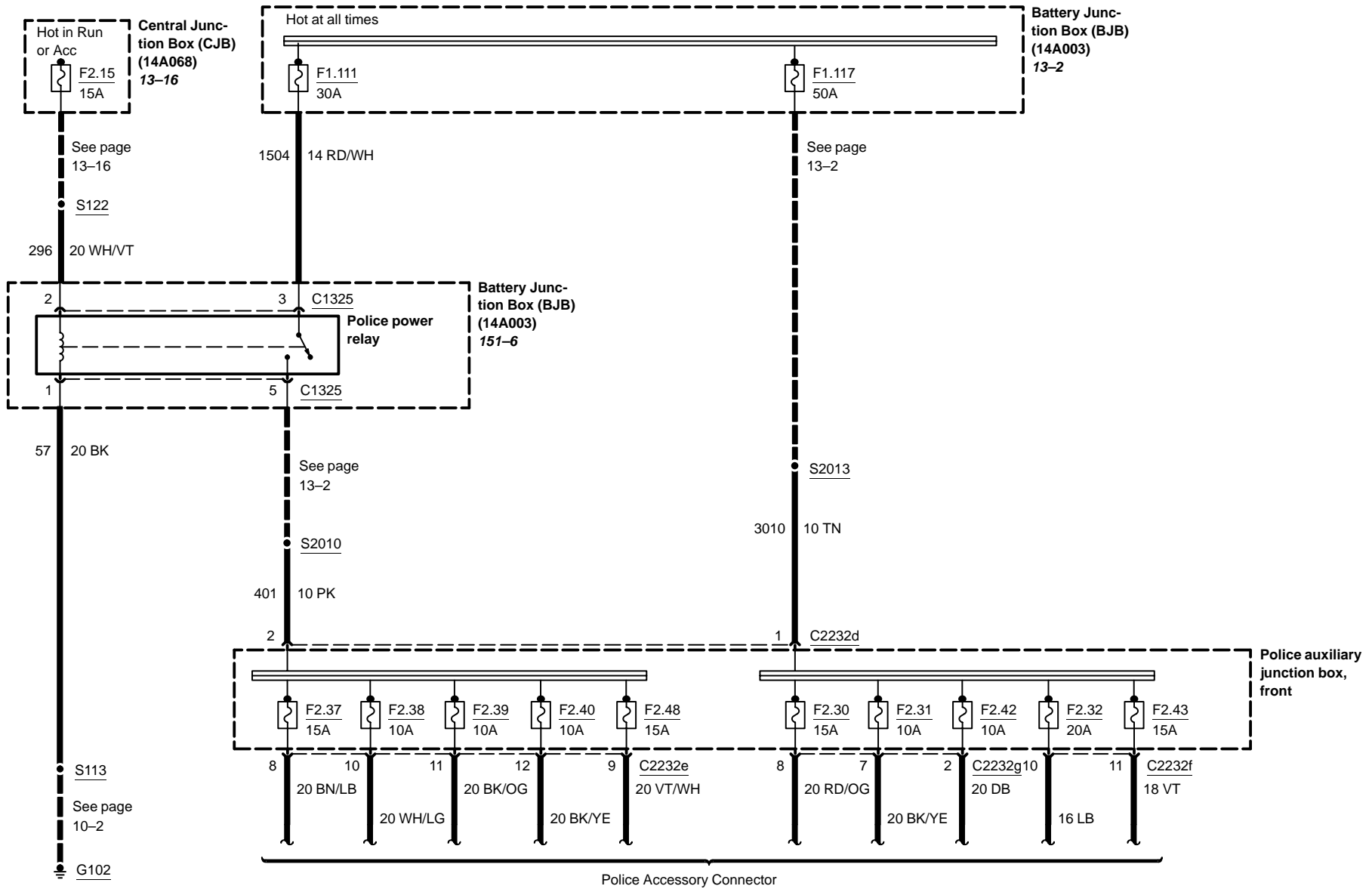

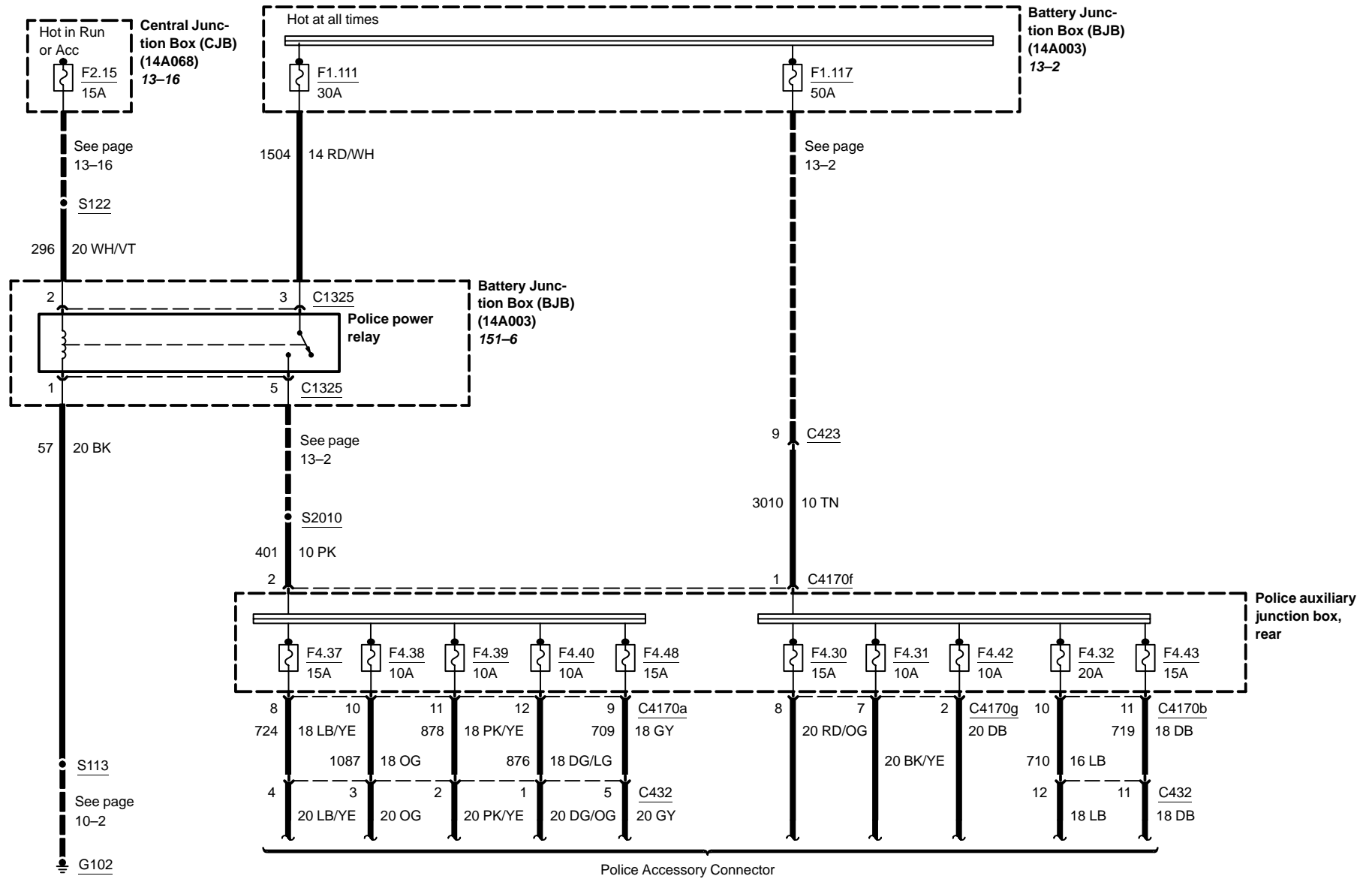

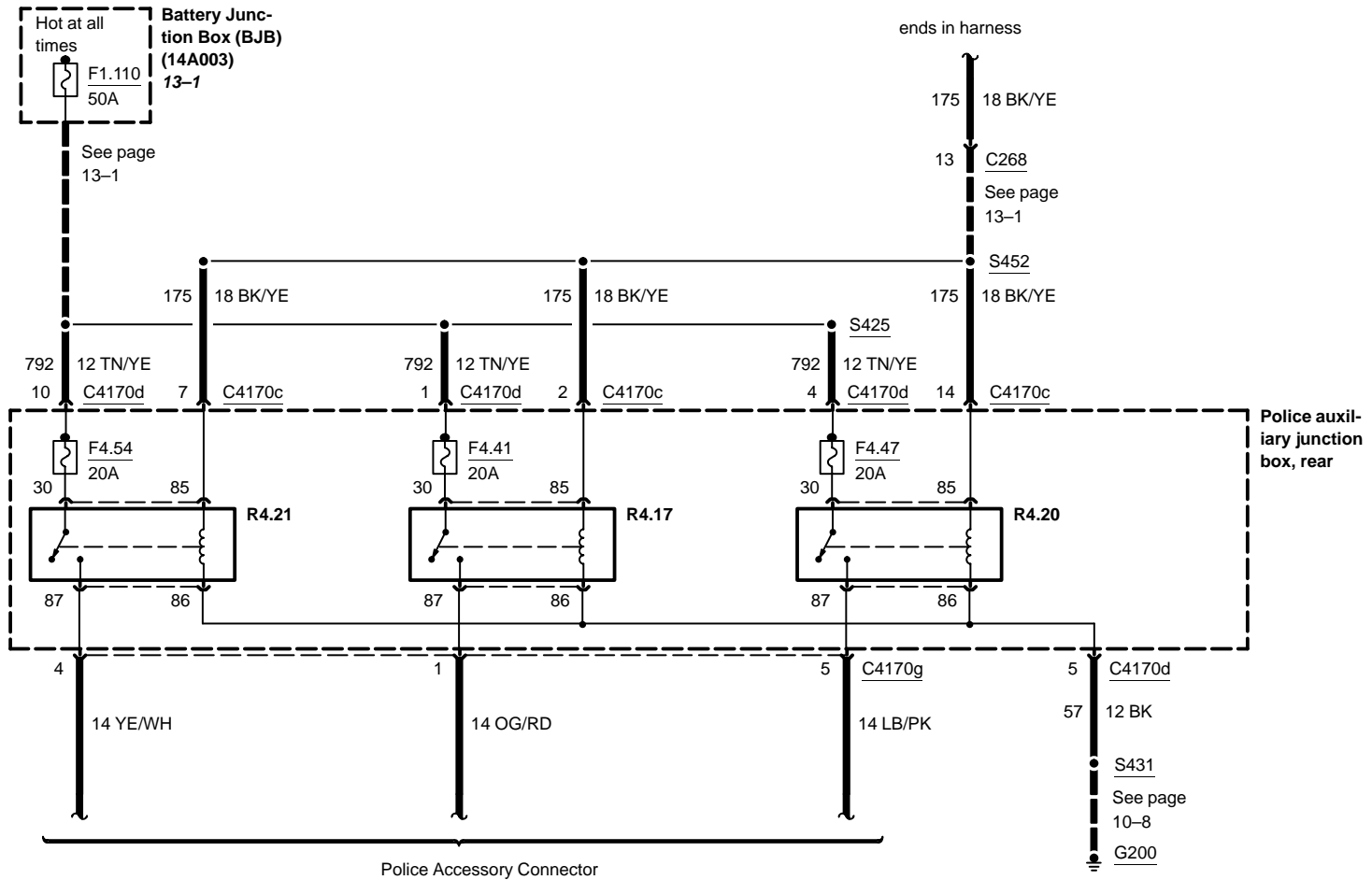

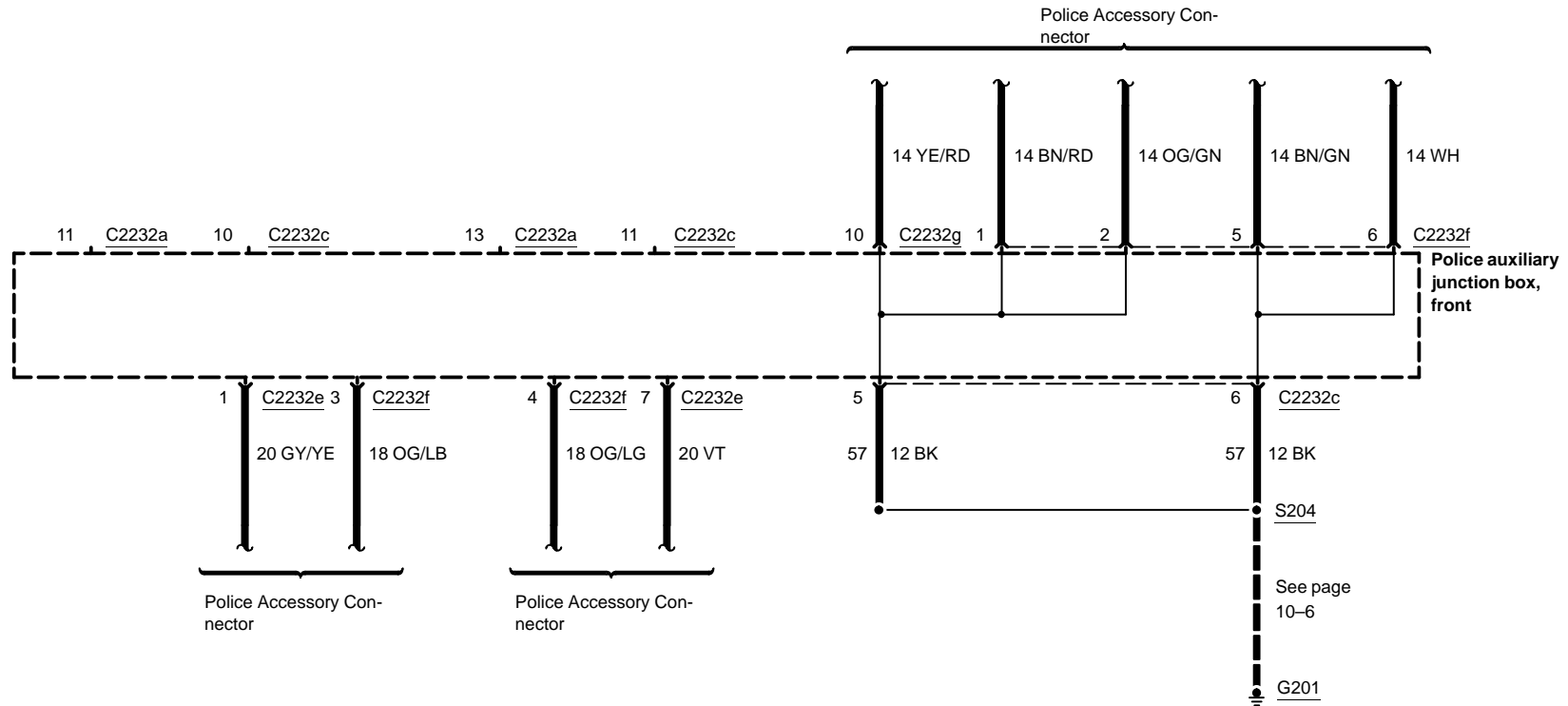

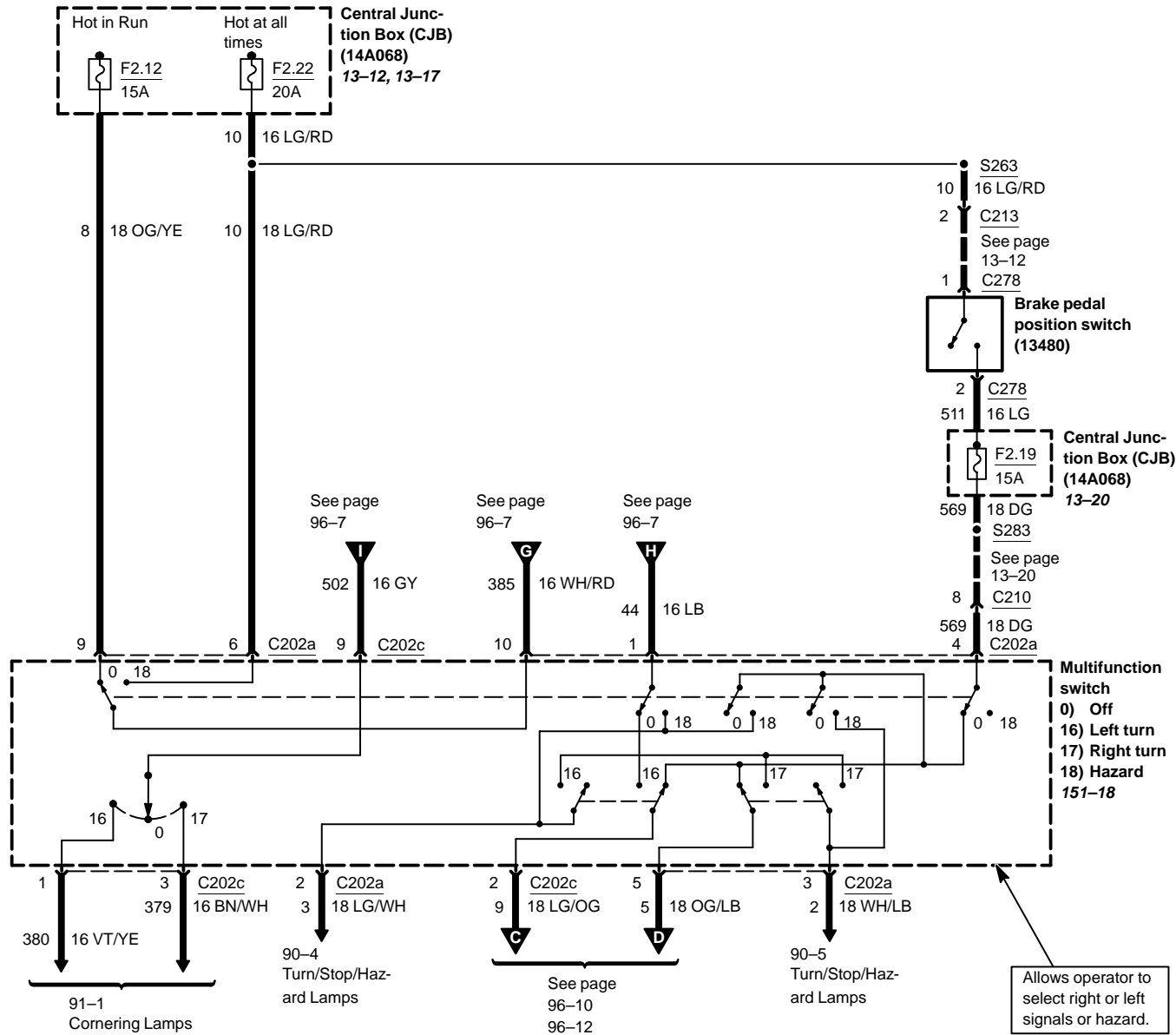

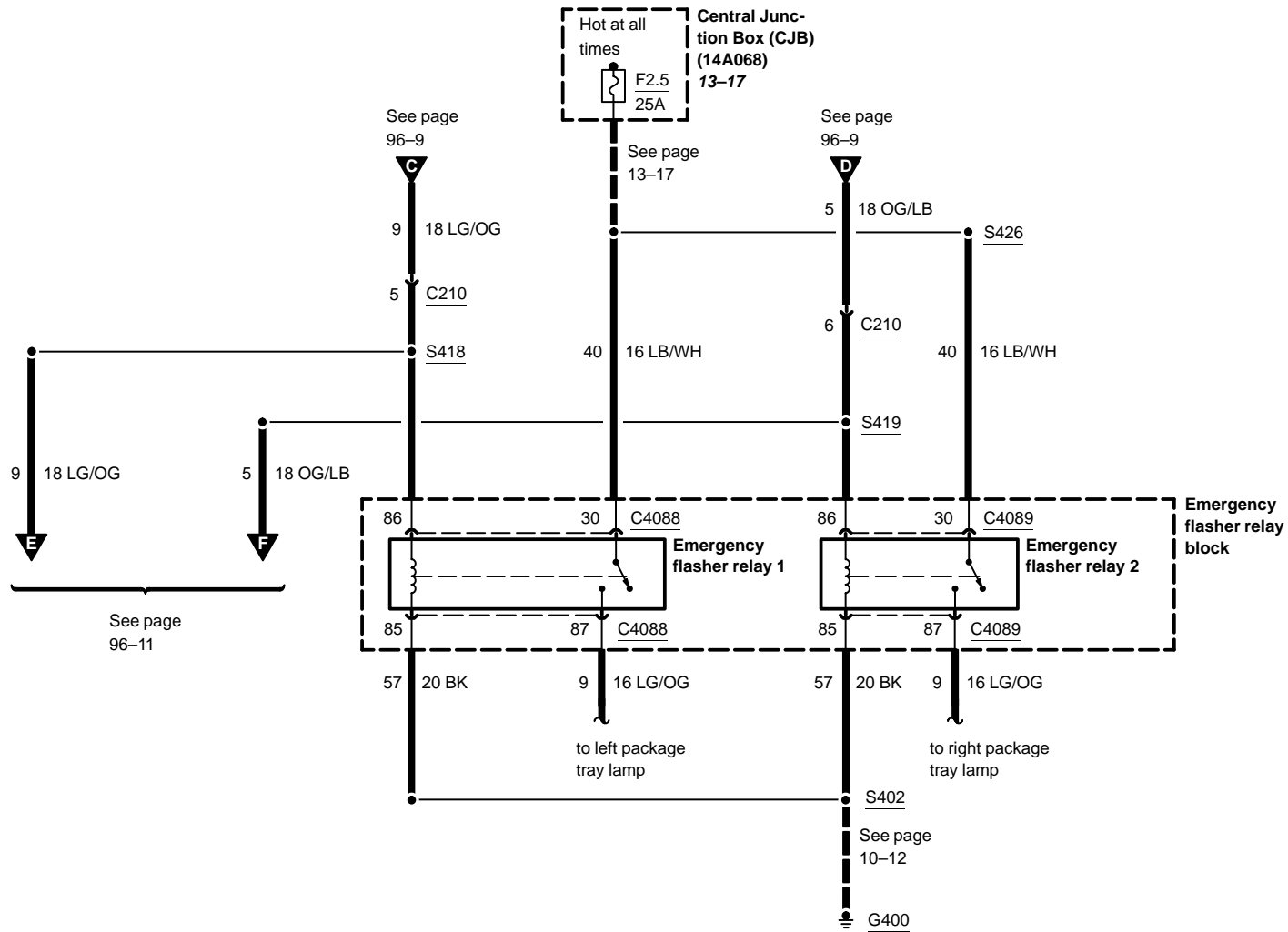

See page
96-10

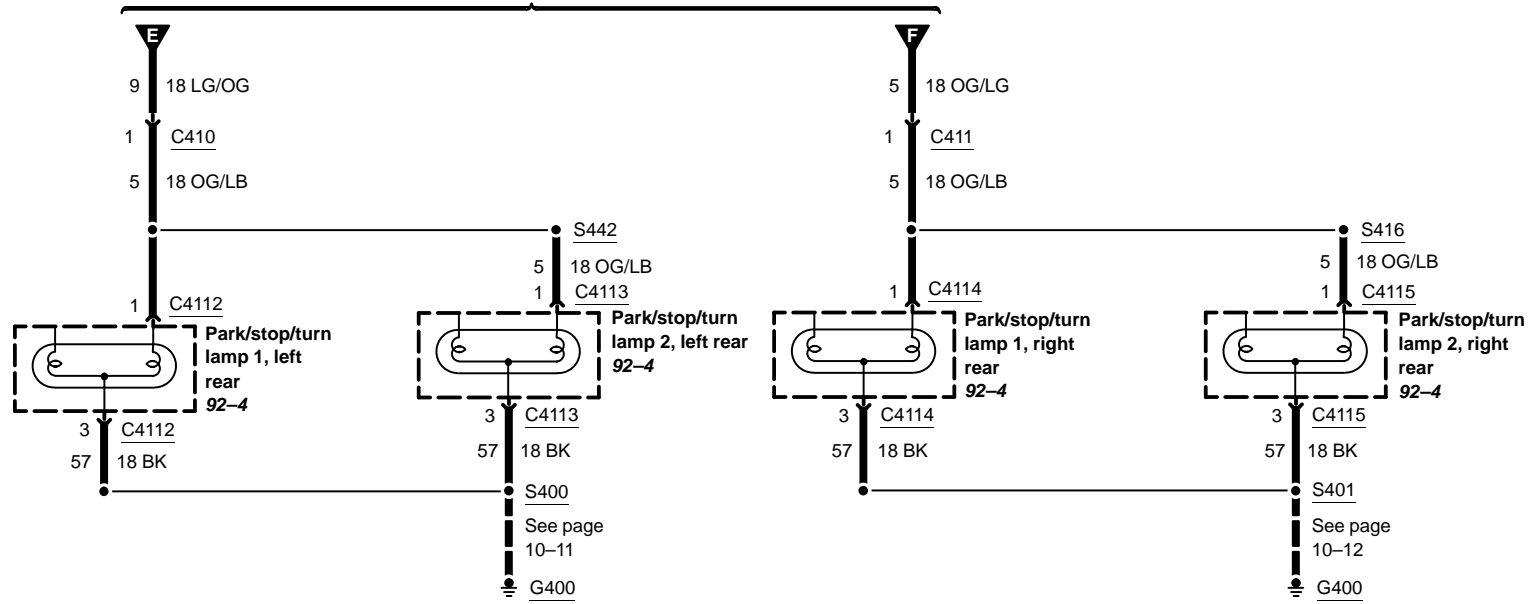

Street Appearance

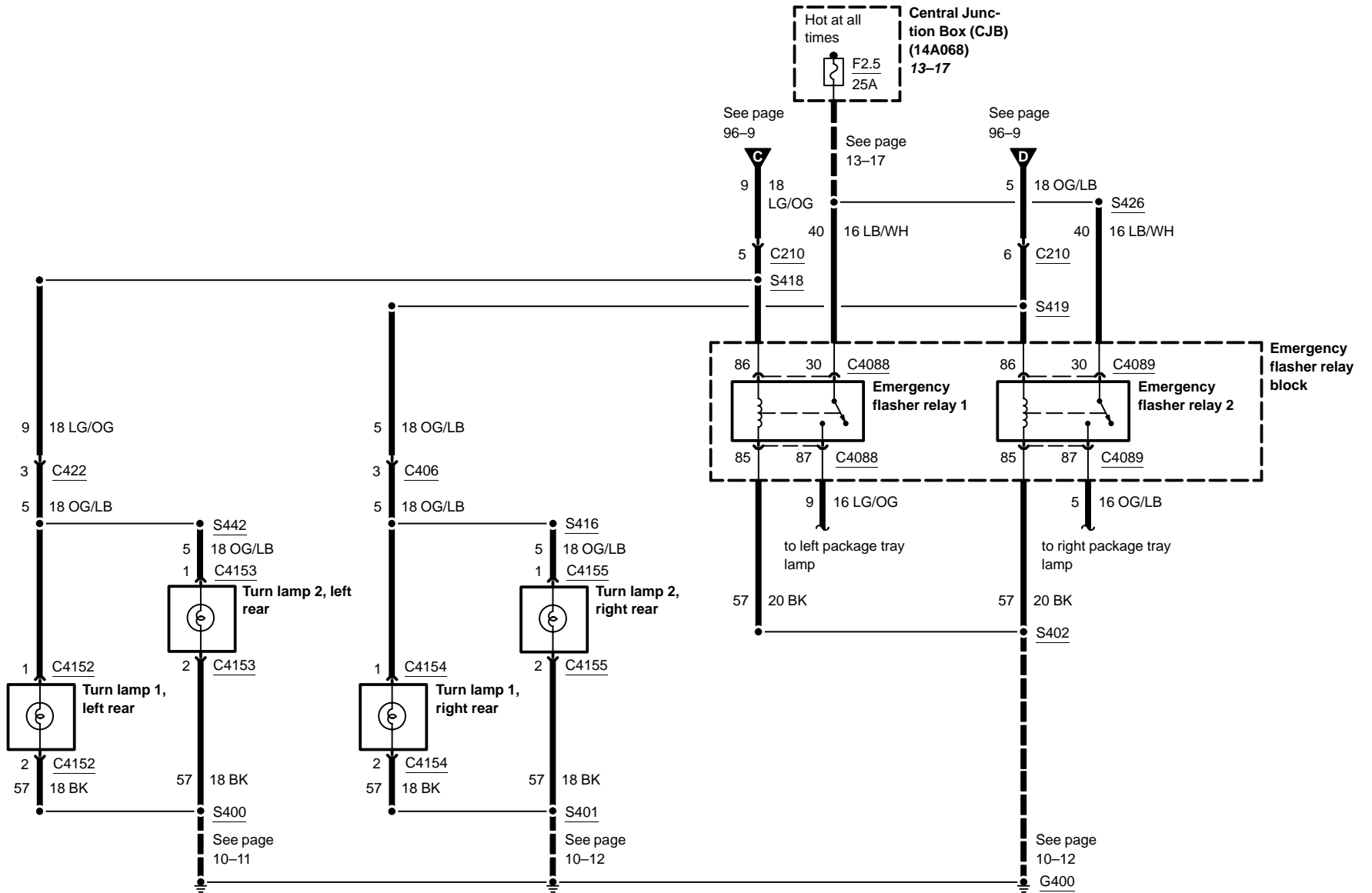

96-13 Police Option

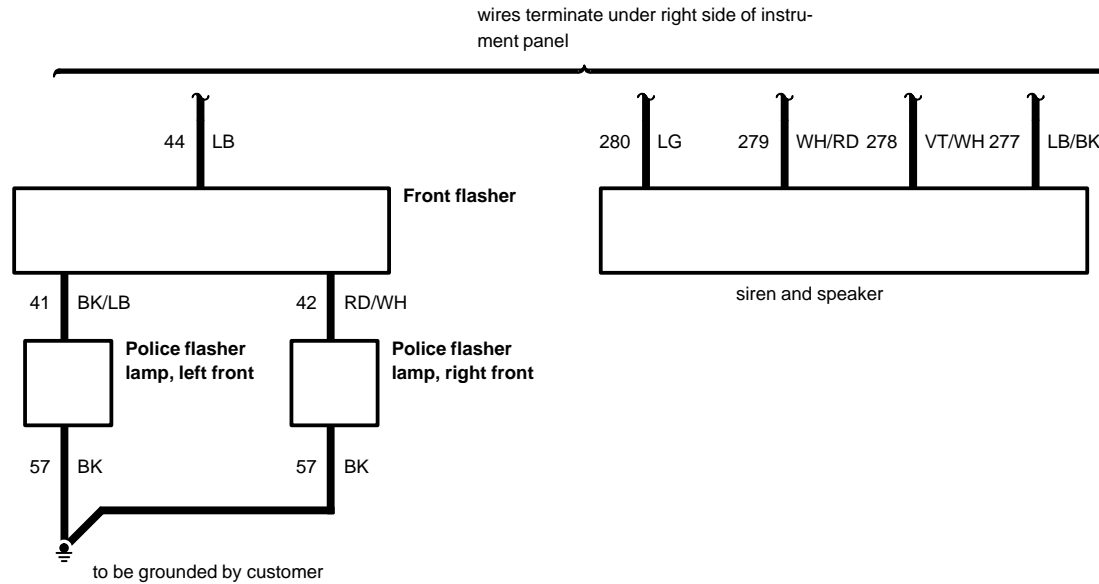
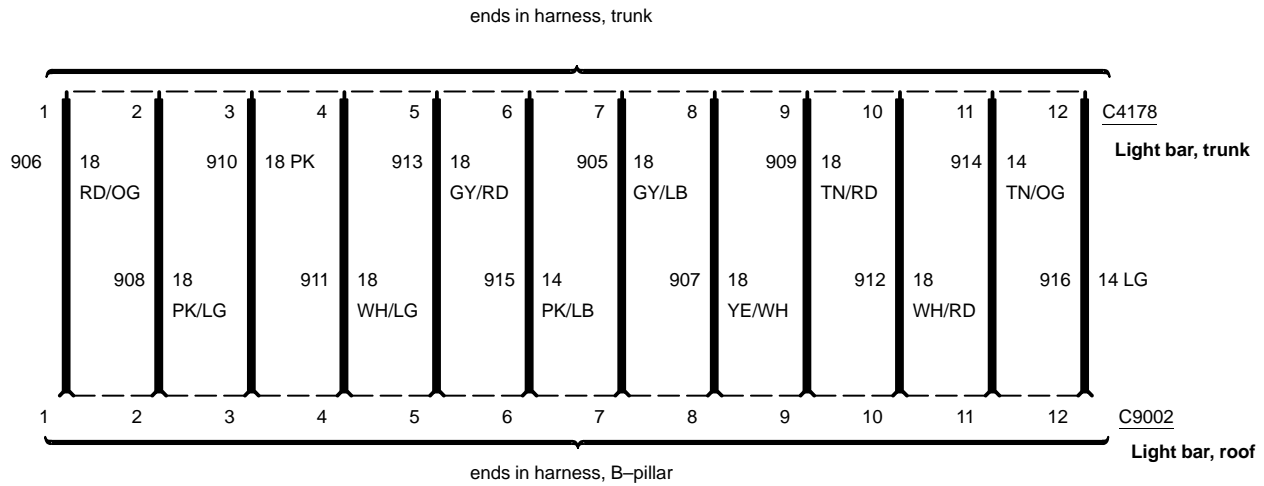
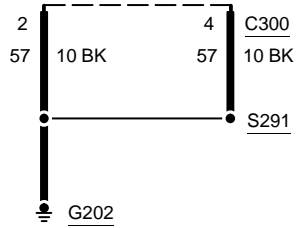
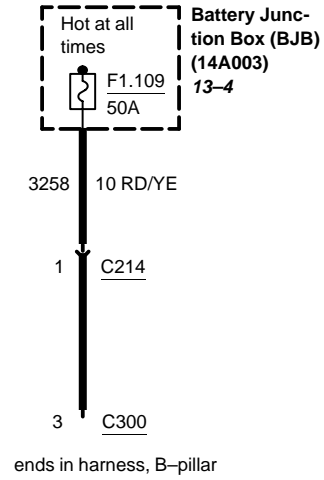

ELECTRICAL POLICE AFTERMARKET EQUIPMENT

SYSTEM	FUSING STRATEGY
• Communications Radio(s)	Acc Feed Wires
• Radio Scanners	Acc Feed Wires
• Radar	Acc Feed Wires
• Computer	Acc Feed Wires
• T.V. Camera, Recorder and Monitor	Acc Feed Wires
• Lojac	Acc Feed Wires
• Vascar	Acc Feed Wires
• Siren	Acc Feed Wires
• Siren activated by Horn Ring (selector switch) (Use Ckt 6 to activate Siren Switch)	Acc Feed Wires
• Electric Shot Gun Lock	Acc Feed Wires
• Roof Lights	Acc Feed Wires
• Extra Writing Light	Acc Feed Wires
• Flashing Headlight	Acc Feed Wires
• Package Tray Lights	Acc Feed Wires
• Under Decklid Lights	Acc Feed Wires
• Flashlight Charger	Acc Feed Wires

CAUTION

- Any Auxiliary Warning Lights, controlled by the Lighting Control Module (LCM), need diode protection to prevent current spike damage to the LCM.
- When installing aftermarket equipment, avoid using fasteners that are too long for the application or in an area which might damage vehicle components, i.e. wiring, brake lines, fuel tank and lines, powertrain components, exhaust system, suspension, etc.
- Also, DO NOT make electrical connectors into the Powertrain Control Module or PCM harness. Connecting into this system may affect engine and transmission operation.
- As an example: Connection of aftermarket electrical equipment into the brake light circuit or any other circuit which is connected to the Powertrain Control Module (PCM), anti-lock brake computer, air bag system or any other vehicle system will cause malfunction.