

Wiring



Impala • Tahoe

WIRING

Impala

CONTROLLED POWER AND SIGNAL CIRCUITS WITH 12 VOLT POWER SUPPLY

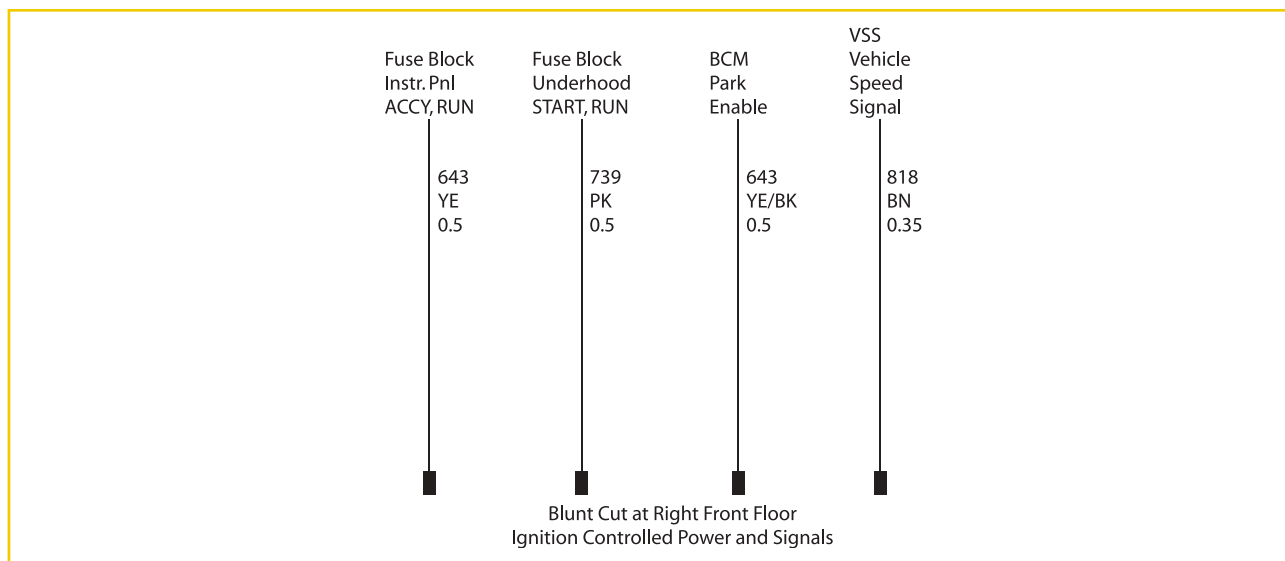

Blunt cut ignition controlled power and signal circuits are also included in the following 5 ft (1.5 m) right foot loop:

- A yellow, 20 gauge (0.5 mm²) 10 amp fused circuit, Hot in ACCESSORY, RUN or RAP (Retained Accessory Power)
- A pink, 20 gauge (0.5 mm²) 10 amp fused circuit, Hot in START and RUN
- A yellow/black, 20 gauge transaxle park signal from the Body Control Module (BCM). The circuit provides a switched power when the transmission is not in PARK (P) and the ignition is turned to ON. The electrical load attached to the park circuit must not exceed 0.5 amps and is meant to drive one relay coil.
- A brown, 22 gauge (0.35 mm²) vehicle speed signal (4,000 pulses/mile) from the ABS module. Connect only high impedance load.

The spotlamp fuses are located in the passenger's side underhood fuse block. See "Fuses and Circuit Breakers" in your owner's manual index for more information.

FUSE BLOCK-SEO

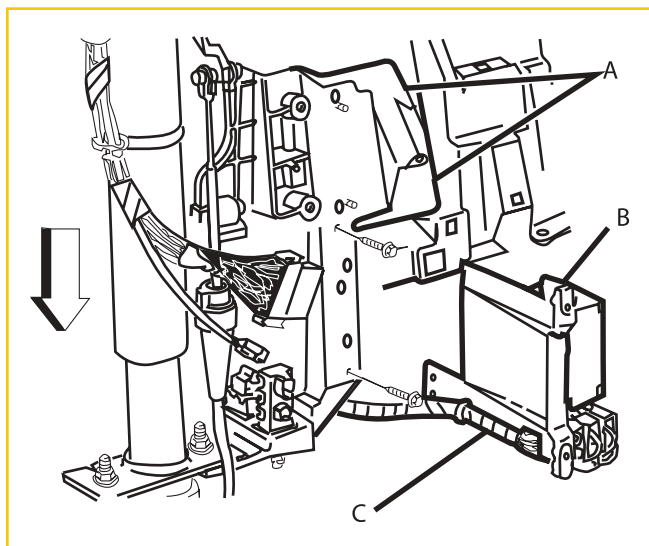

Servicing Relays and Circuit Breakers

The following information shows you where the relays and circuit breakers are located in the Fuse Block-SEO.

- A. Instrument Panel Carrier
- B. Relay Center for Circuit Breakers and Control Relay
- C. Instrument Panel Harness Branch

ENLARGED VIEW OF THE SEO FUSE BLOCK

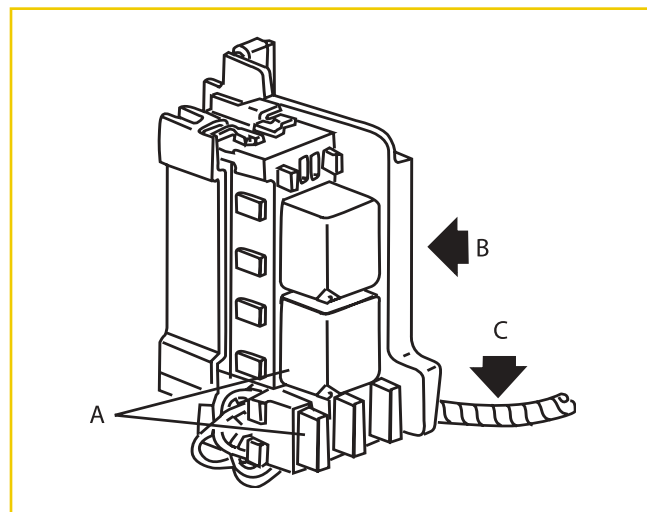

- A. Relays and Circuit Breakers
- B. Front of the Vehicle
- C. Floor of the Vehicle

WIRING

Impala

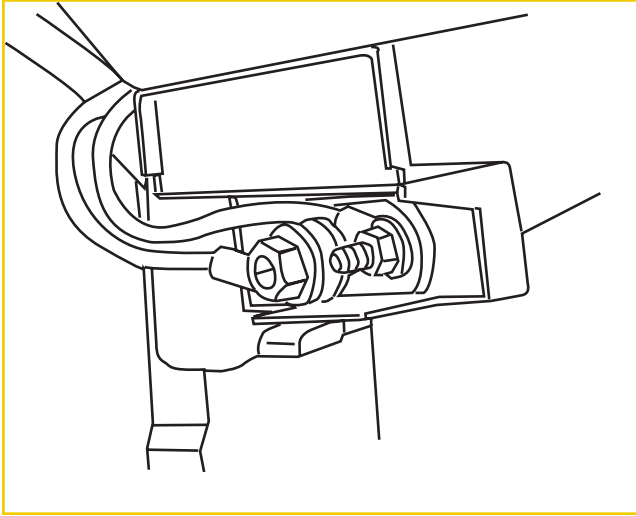

Trunk Auxiliary Battery Power Junction Block

The auxiliary battery power junction block is mounted in the trunk of your Impala police vehicle. It is located on the passenger side support strut behind the rear wheel housing.

This junction block is split to provide two circuits and can be used to connect customer-furnished equipment directly to the battery through fusible links. A maximum of 100 amps (1200 watts) can be connected. Torque the connections to the studs to 11 lb ft (15 m). It is fed by two fusible links of 50 amps each.

To connect the customer-furnished equipment at the junction block, use the following steps:

1. Disconnect the negative (-) battery cable.
2. Connect the customer-furnished equipment positive leads to the junction block terminals and tighten to 11 lb ft (15 N·m).

The ignition must be turned off and the vehicle vacated prior to connecting the negative (-) battery cable to the battery.

3. Reconnect the negative (-) battery cable to the battery.
4. Set the time on the clock and radio pushbuttons as needed. See "Audio Systems" in the Instrument Panel section of your Impala owner's manual for more information.

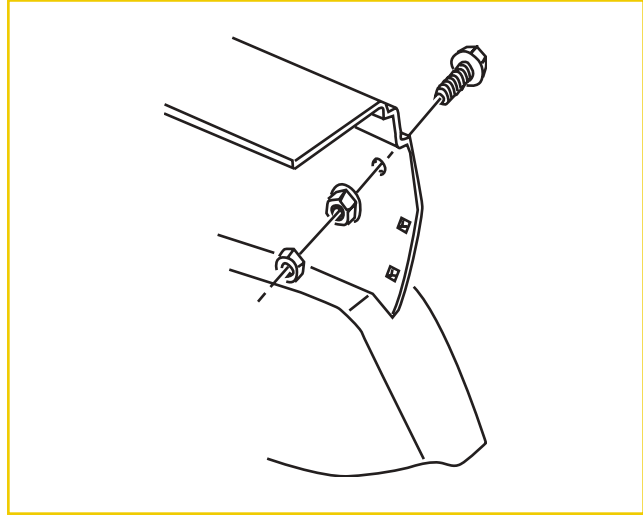

Trunk Ground Stud – SEO UT7

A 10 mm ground stud can be found in the trunk on the passenger's side of the vehicle. The stud is located above the trunk auxiliary junction block. See "Trunk Auxiliary Battery Power Junction Block" that follows for more information on location. A 10 mm flanged hex nut grounds the 10 mm bolt to the vehicle. Recommended torque for the flanged nut is 26 lb ft (35 N·m), plus or minus 4 lb ft (5 N·m). A 10 mm hex nut is provided for customer ground termination. Recommended torque for the terminal connection nut is 7.3 lb ft (10 N·m), plus or minus 1 lb ft (1.3 N·m).

WIRING

Impala

WIRING DIAGRAM FOR AUXILIARY BATTERY POWER JUNCTION BLOCK

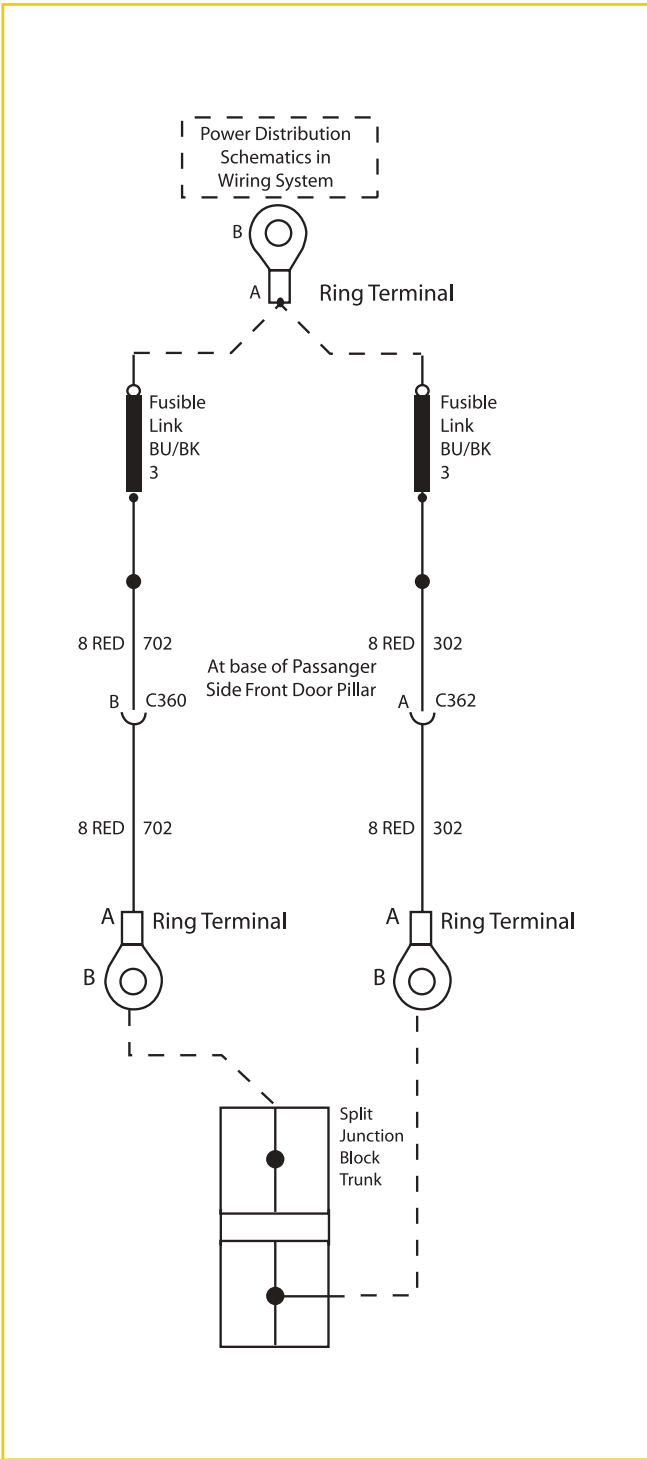

WIRING

Impala

Wiring Provisions for Vehicle Grille Lamps, Flasher and Speaker/Siren – SEO 6J3

WIRING HARNESS WITH ALTERNATING SIGNAL FLASHER

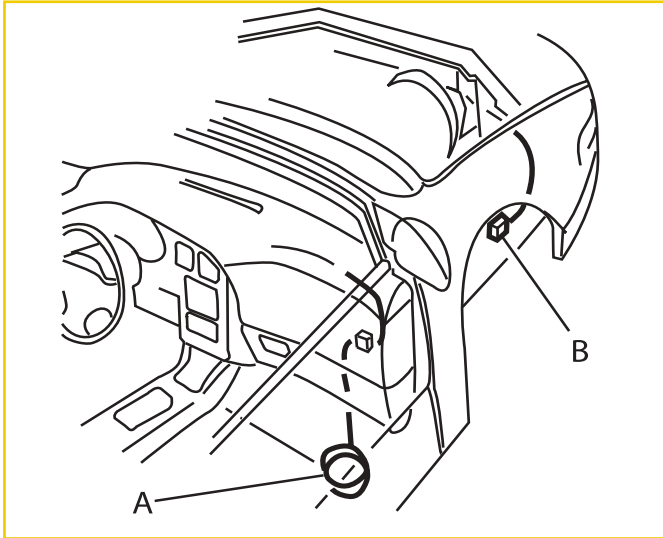

- A. Blunt cut ends for the Alternating Signal Flasher, Customer-Furnished Grille Lamps and Customer-Furnished Siren/Speaker
- B. Control Wires from In-Line Connector in Forward Lamp Harness for Customer-Furnished Grille Lamps and Speaker

This wiring provision option consists of one 16 gauge (1.0 mm) wire connected to an alternating signal flasher located underneath the instrument panel on the passenger's side. Five feet (1.5 m) of extra wire from the flasher is routed from underneath the instrument panel to an area behind the grille. All four wires have 12 inches (30 cm) of extra wire in a coil behind the grille. Grille lamps and the speaker are not included. The flasher is not included when SEO 6J7 is ordered without SEO 6J3.

ALTERNATING SIGNAL FLASHER

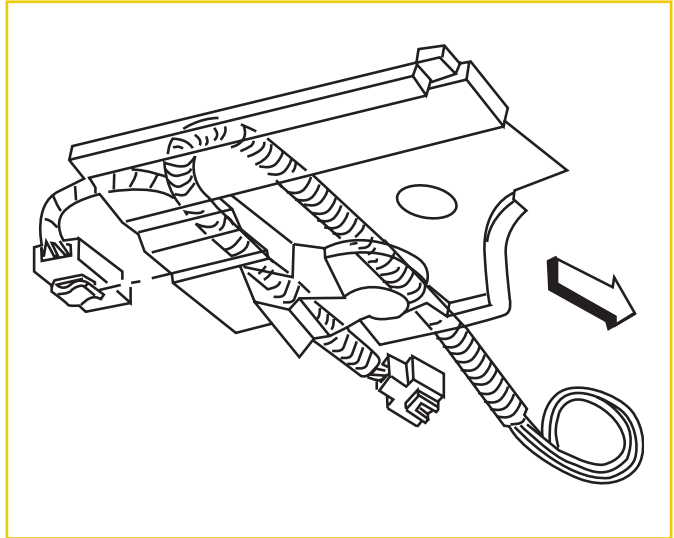

The SEO 6J3 wiring provision also includes control wiring for the SEO 6J7 exterior lamps emergency flashing system. A dark green/red 18 gauge (0.8 mm) headlamps flasher module control wire activates the flashing system when 12-volts are applied.

When SEO 6J7 is installed without SEO 6J3, only the dark green red control wire is provided for connection to customer-furnished 12-volt switching to turn the emergency flashing system on or off.

WIRING DIAGRAM FOR SEO 6J3 SEO 6J7

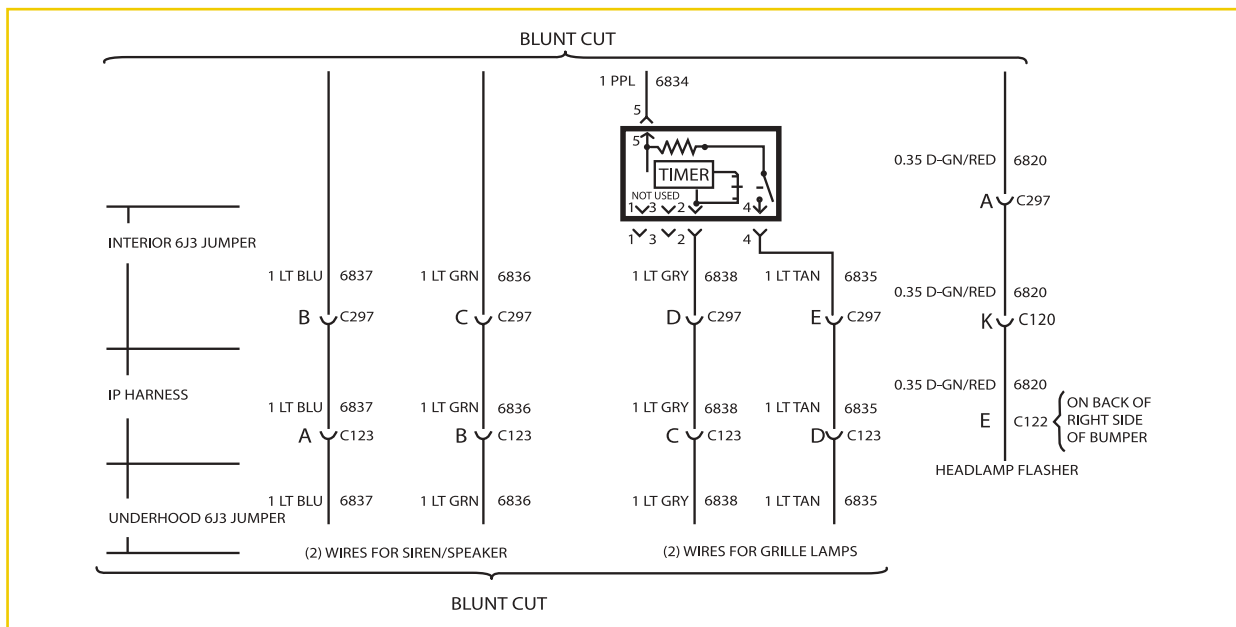

WIRING

Impala

Exterior Lamp Emergency Flashing System—SEO 6J7

SEO 6J7 provides a high-beam headlamps flashing module, rear lamps flashing and control wire for a customer-furnished switch to turn the module on or off. The flasher control wire is coiled in the passenger's side footwell under the instrument panel. This control lead may be combined with the interior wiring leads for SEO 6J3 when that option is ordered with SEO 6J7.

The headlamps flashing module is located at the inboard end of the passenger's side headlamps assembly. The headlamps flashing module is activated by the application of 12 volts to a dark green/red wire coiled in the passenger's side footwell. When activated, the driver's and passenger's side high-beam headlamps and the high-beam instrument panel cluster light will flash alternately at 2.4 flashes per second.

During daylight conditions, the Daytime Running Lamps (DRL) are automatically turned off whenever the headlamps flasher module is activated. During nighttime conditions, the low-beam headlamps turn on automatically while the high-beam headlamps flash. Turning on the high-beam headlamps manually with the turn signal/multifunction lever will override the flashing module and the high-beam headlamps will operate continuously.

A fuse labeled HDLP MDL protects the flasher module circuit. This fuse is located in the underhood fuse block in the engine compartment on the passenger's side of the vehicle. See "Fuses and Circuit Breakers" in

the Service and Appearance Care section of your Impala owner's manual for more information.

When the headlamps flashing module is turned on, the module sends a signal to the Body Control Module (BCM). The BCM alternately flashes the stop lamps and backup lamps. Depressing the brake pedal will override the stop lamp flashing and placing the transaxle in reverse will override the backup lamp flashing.

Activation of the headlamp and rearlamp flashing can be separated. Call Kerr Industries at 905-725-6561 for instructions.

When it is dark outside, the tail lamps will turn on automatically. The Center High-Mounted Stoplamp (CHMSL) will not flash and will operate only when the regular brake pedal is pressed.

HEADLAMPS FLASHER MODULE—SEO 6J7

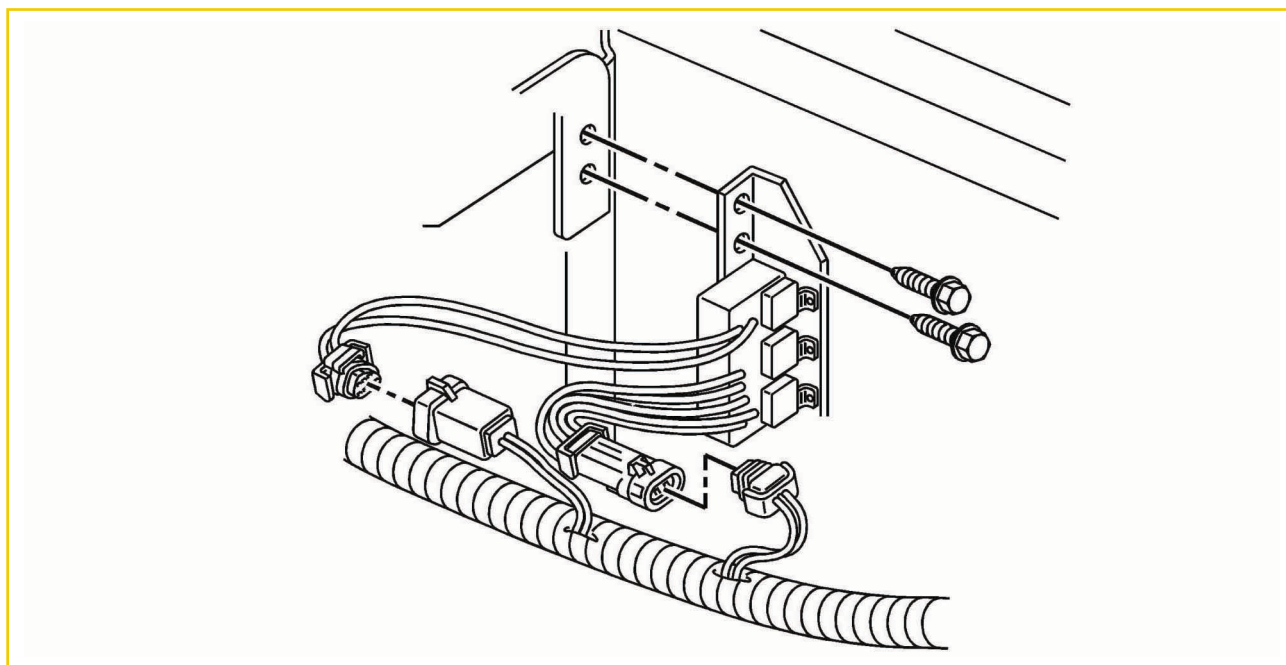

WIRING

Impala

FORWARD LAMP HARNESS IN-LINE CONNECTOR FOR USE WITH HEADLAMPS FLASHER MODULE, OPTION 6J7

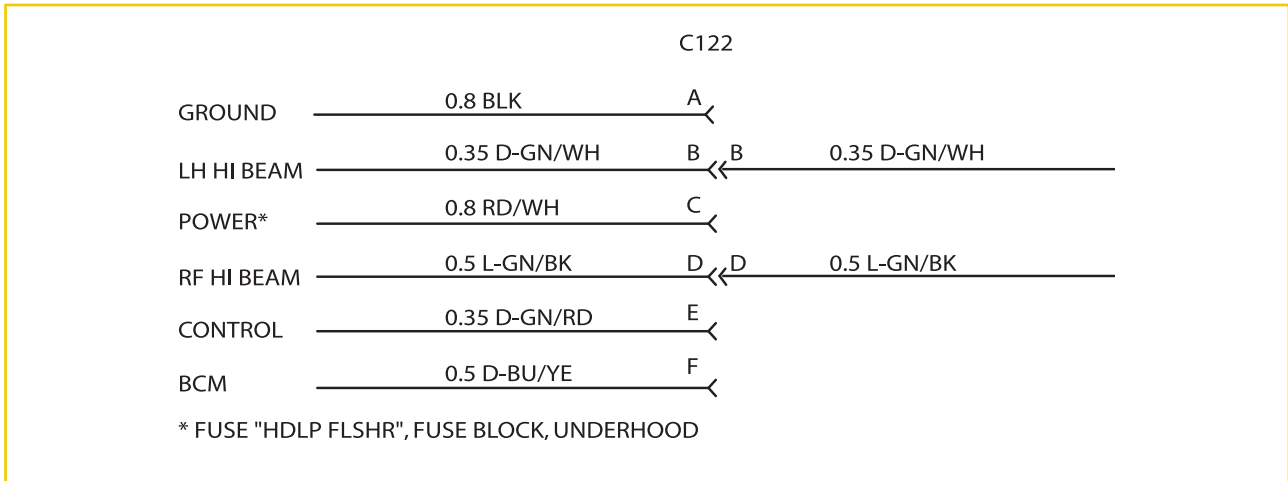

This connector is located at the rear passenger side of the bumper beam.

WIRING PROVISION FOR HORN/SIREN CIRCUIT – SEO 6J4

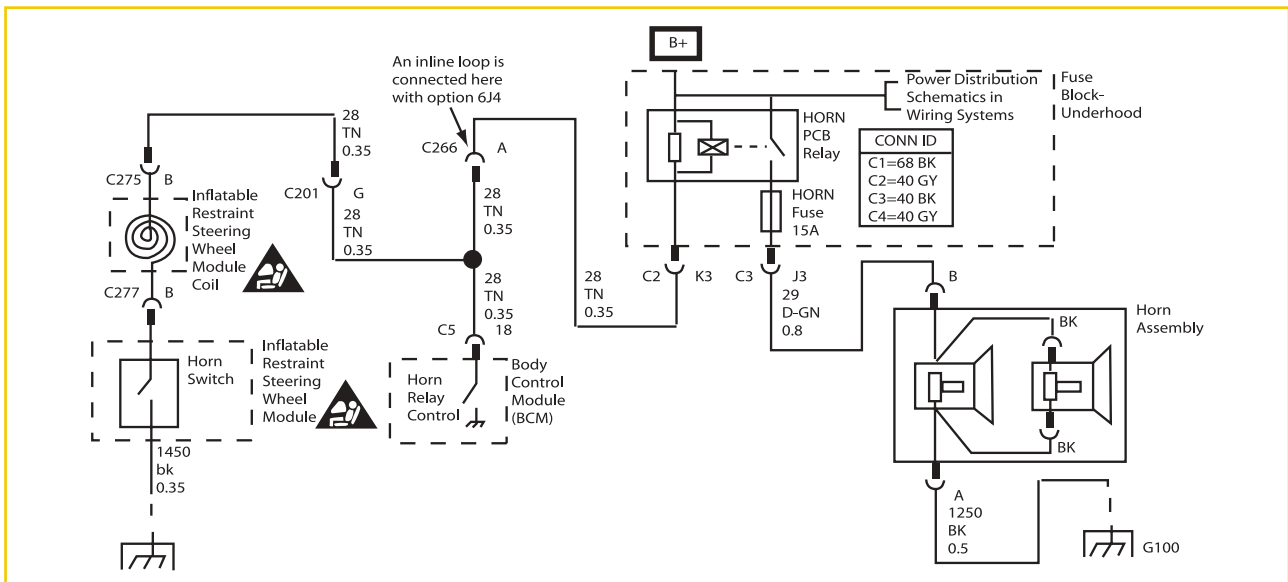
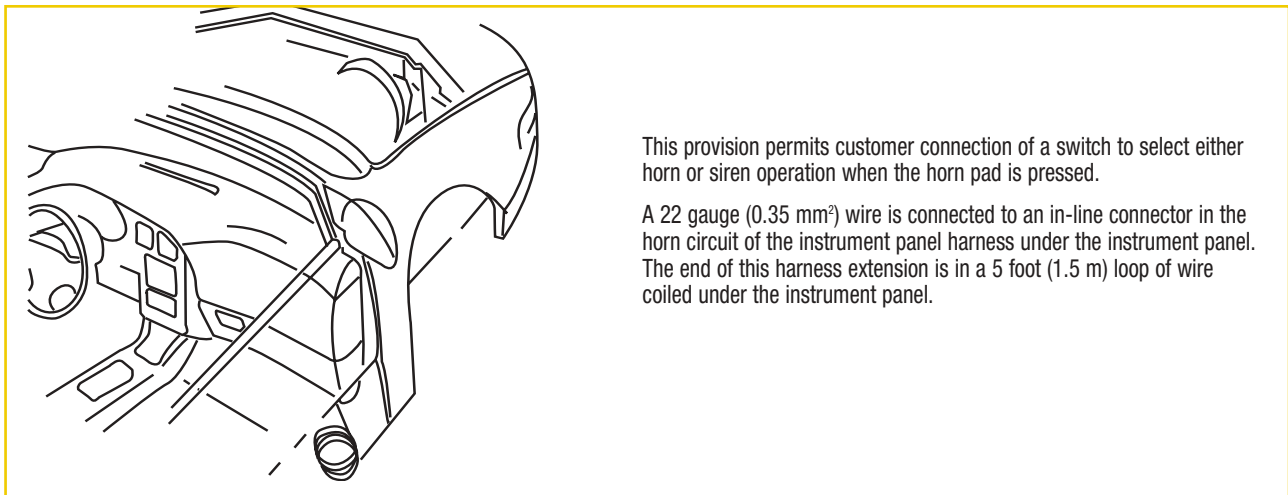

WIRING

Impala

WIRING DIAGRAM FOR ROOF-MOUNTED ACCESSORIES – SEO 6F5

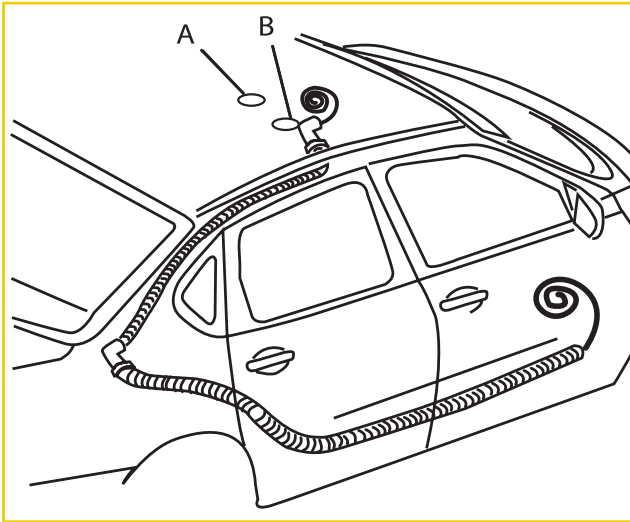

Option 6F5 is a universal wiring harness for roof-mounted equipment. The harness is routed from a 5 foot (1.5 m) coil of wire in the passenger's side footwell to a connector on the passenger's side of the trunk.

When the SEO 6B7 (center hole) is ordered, two color coded 10 gauge (5.0 mm²) wires extend 24 inches (60 cm) through a grommet approximately 30 inches (74 cm) behind the top of the windshield at the center of the roof.

When SEO 6J5 (passenger's side hole) is ordered, two color-coded 10-gauge (5.0 mm²) wires extend 24 inches (60 cm) through a grommet approximately 30 inches (74 cm) behind the top of the windshield and 6 inches (15 cm) inboard from the passenger's side roof joint.

WIRING DIAGRAM FOR SEO 6F5

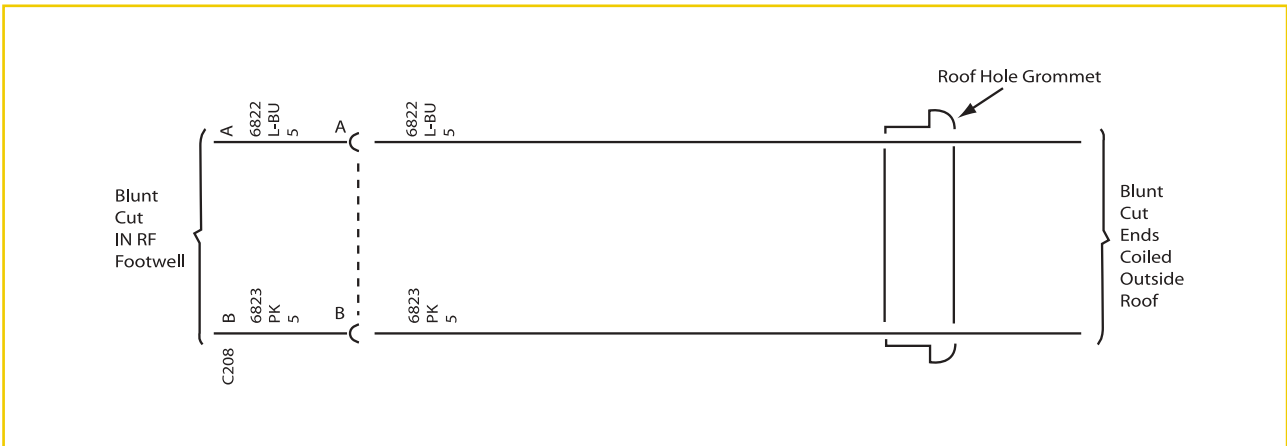

WIRING

Impala

WIRING PROVISIONS FRONT SPEAKERS – SEO WX7

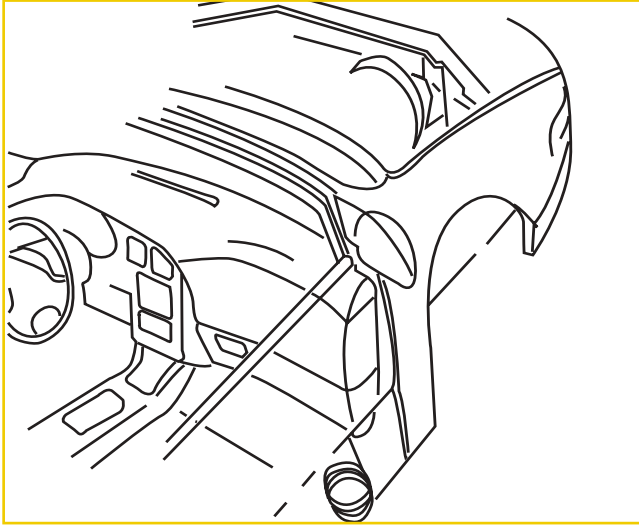

Approximately 65 inches (165 cm) of auxiliary speaker wire is run from the instrument panel radio connector and is coiled under the center of the instrument panel. The wiring permits the connection of front door speakers to customer-installed communication equipment.

Radio outputs from the front speakers are sent to the rear speakers to maintain the required open door/key in the ignition reminder chime.

Electrical Connections

1. Disconnect the negative (-) battery cable at the battery.
2. Remove the tape from the wire coiled under the instrument panel to uncoil it.
3. Using proper electrical connectors, connect the wires for the left front audio output of the customer-installed communication device. The left front positive wire is tan and the left front negative wire is gray.
4. Using proper electrical connectors, connect the wires for the right front audio output of the customer-installed communication device. The right front positive wire is light green and the right front negative wire is dark green. The electrical impedance of each speaker installed is 10 ohms.

NOTICE: OVERLOADING THE VEHICLE'S ELECTRICAL SYSTEM MAY DAMAGE YOUR VEHICLE'S ACCESSORIES. DO NOT OVERLOAD THE VEHICLE'S SYSTEM BY HAVING UNNECESSARY ACCESSORIES ON AT THE SAME TIME.

5. The ignition must be turned off and the vehicle must be vacated prior to attaching the cable to the battery. Connect the negative (-) battery cable to the battery and tighten the bolt to 11 lb ft (15 N-m).
6. Set the time on the clock and radio pushbuttons as needed. See "Audio Systems" in the Instrument Panel section of your Impala owner's manual for more information.

WIRING DIAGRAM FOR SEO WX7 INLINE CONNECTOR

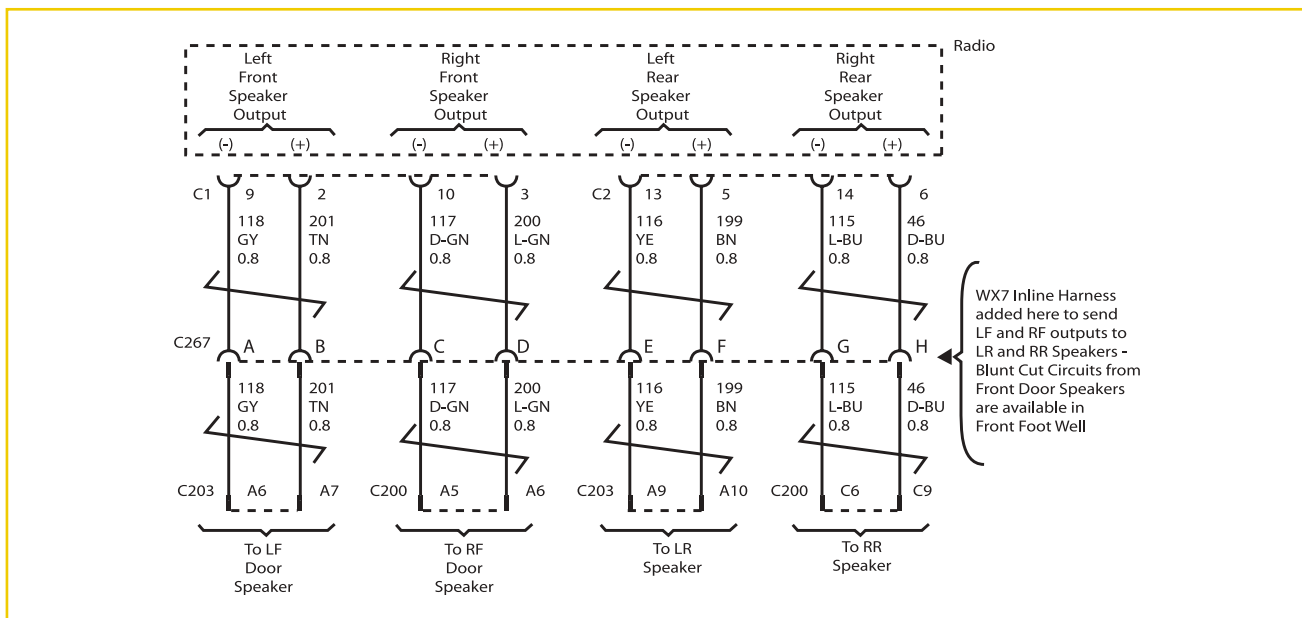

WIRING

Tahoe

WIRING PROVISIONS FOR 12-VOLT BATTERY POWER SUPPLY

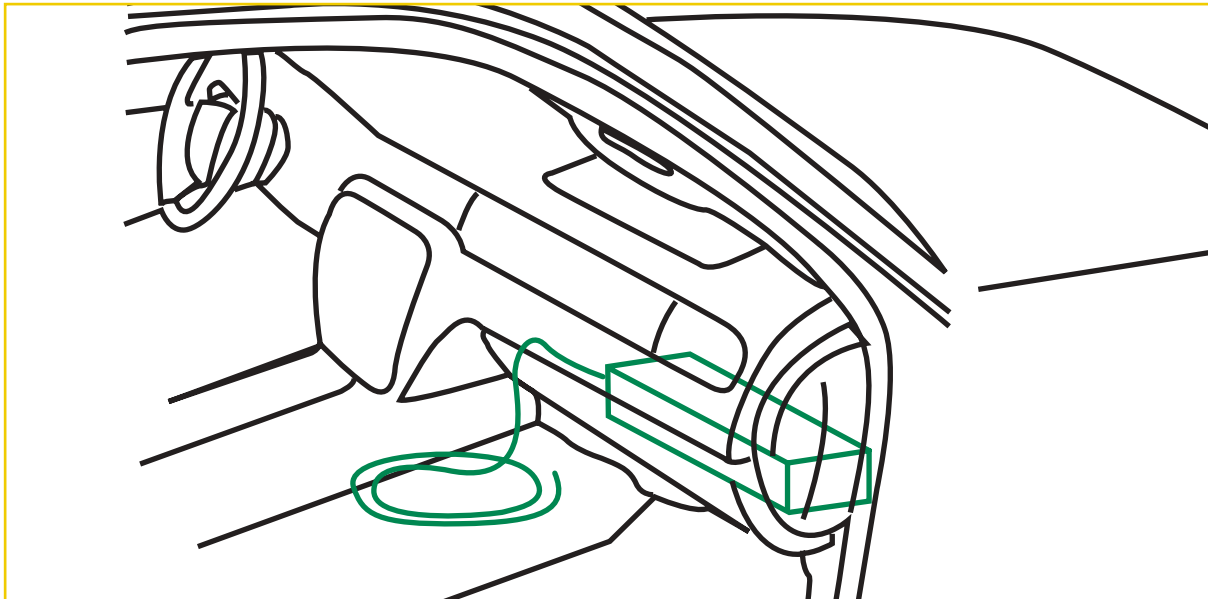

Your vehicle is equipped with wiring provisions for a 12-volt battery power supply. Refer to the following information when adding electrical system. The wiring harness is located below the instrument panel near the center of the vehicle. The following information describes the breaker and relay location and provides a wiring diagram to aid in connecting customer equipment.

The 12-volt battery power is supplied through two underhood mega fuses, one 125 amp and one 60 amp. This underhood power is fed to the breaker/relay center via a harness that passes through the driver side front of the dash, and routed across the instrument panel to a position forward of the glove box. The breaker/relay center is mounted to the instrument panel structure forward of the glove box. The center includes a plastic bracket, two relays, two 30-amp breakers and three 50-amp mega circuit breakers.

Two 30 amp breakers supply power from the underhood 60 amp mega fuse through the contacts of the control relays to a 12 gauge (3.0. mm²) blunt cut wires. These two blunt cut leads are part of wire coiled under the instrument panel near the center of the vehicle.

Each relay is operated by a 0.5 mm² blunt cut, light or dark blue control lead included in a 3 foot (91 cm) loop of wire under the instrument panel.

Three 50-amp mega circuit breakers, protected by three fusible links, supply power directly from the underhood 125-amp mega fuse through three, 10-gauge (5.0 mm²) wires. Two of the wires are routed through the body harness to a split buss junction block to the left rear of the cargo area and secured near the jack and tools. This 3 foot (91 cm) of coiled wires can be accessed by removing the cup holder on the top of the trim panel. The third 10-gauge wire is a blunt cut lead, which is part of the 3-foot (91 cm) loop of wire coiled under the instrument panel near the center of the vehicle.

An 8-gauge (8 mm²) ground lead is also provided and it is located under the front passenger sill plate. It can be accessed by removing the sill plate and pulling the loop of wire at the front of the plate, the lead is 3 feet (91 cm) long.

Blunt cut ignition control power and signal circuits are also included in the wire coiled under the instrument panel near the center of the vehicle. They include:

- A yellow, 20 Gauge, 10 amp fused circuit, Hot in ACCESSORY, RUN, or RAP (Retained accessory Power).
- A pink, 20 Gauge, 10 amp fused circuit, Hot in START and RUN
- A Yellow/black, 20 Gauge transmission park signal from the Body Control Module (BCM), the circuit provides switched power when the transmission is in PARK (P) and the engine is running. The electrical load attached to the park circuit must not exceed 0.5 amps (6 watts) and is meant to drive only one relay coil.
- A dark green/white, 20 gauge Vehicle Speed Signal (VSS) provides 4,000 pulse per mile.

The breaker and relay center is located behind and above the instrument panel storage compartment. Remove contents from the storage tray. Using the tab at the back of the compartment drop the tray down gently toward the floor. You will find the breaker/relay center above the right rear corner of the storage compartment. The bracket is attached to the instrument panel structure with two screws. It will hang from the hinge.

WIRING

Tahoe

WIRING DIAGRAM FOR 12-VOLT BATTERY POWER SUPPLY AND AUXILIARY BATTERY POWER JUNCTION BLOCK

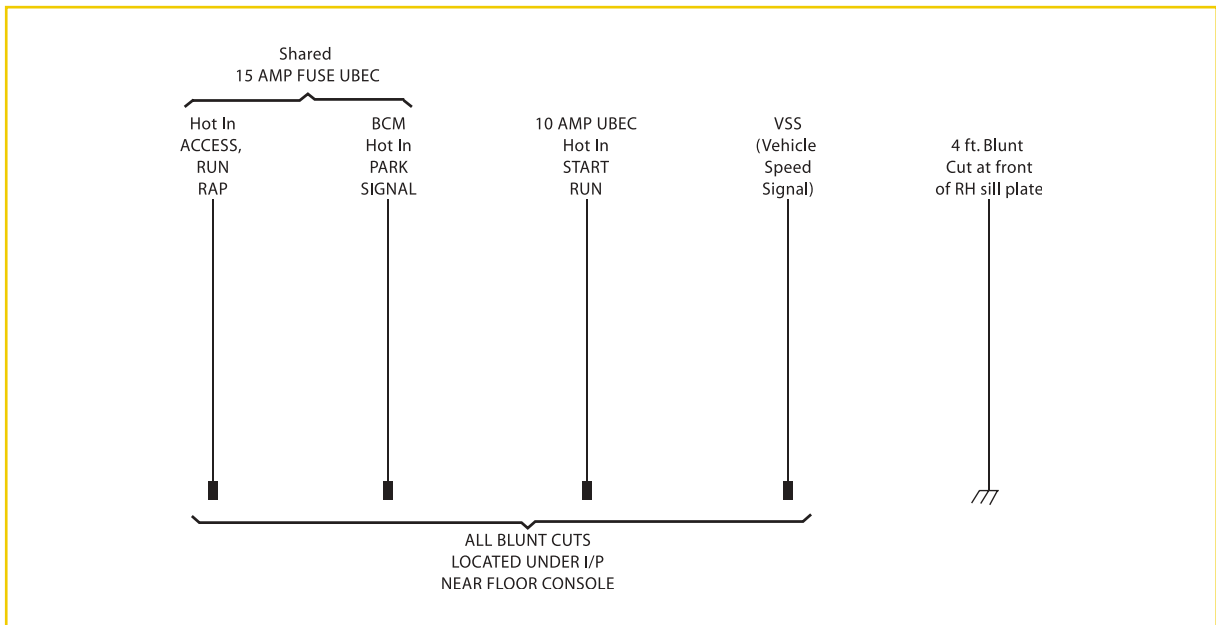
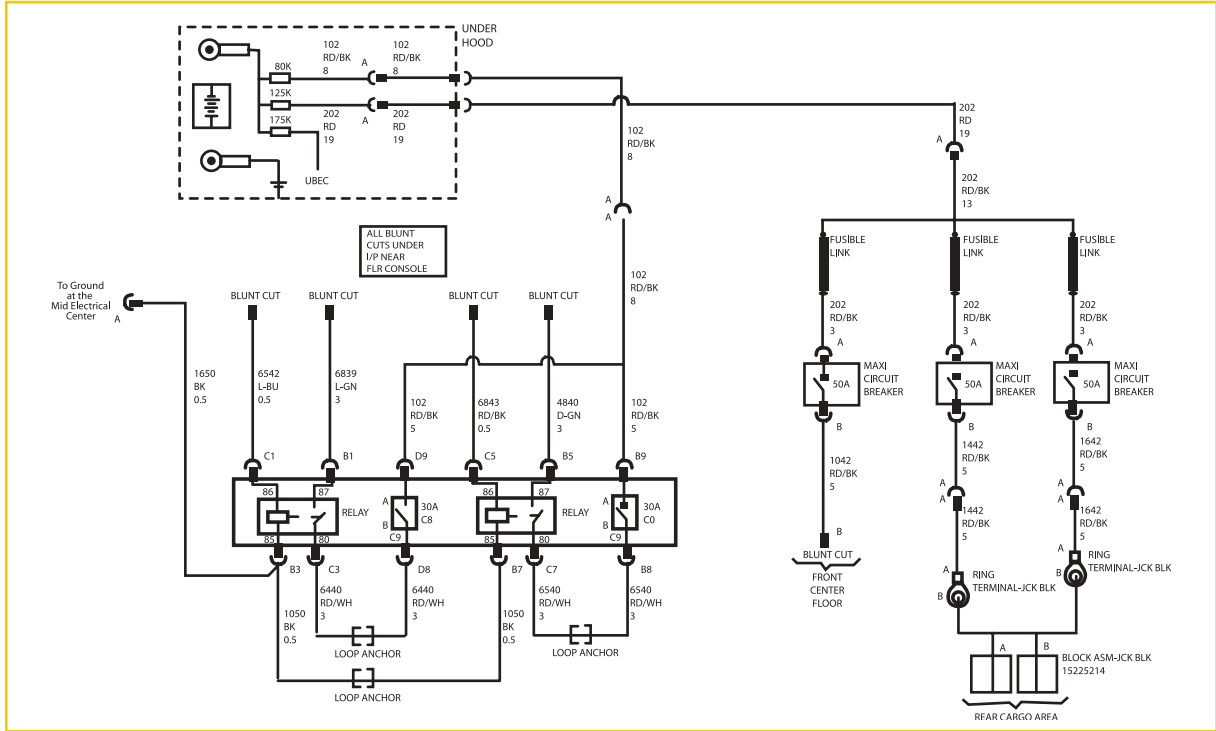

WIRING

Tahoe

AUXILIARY BATTERY POWER JUNCTION BLOCK

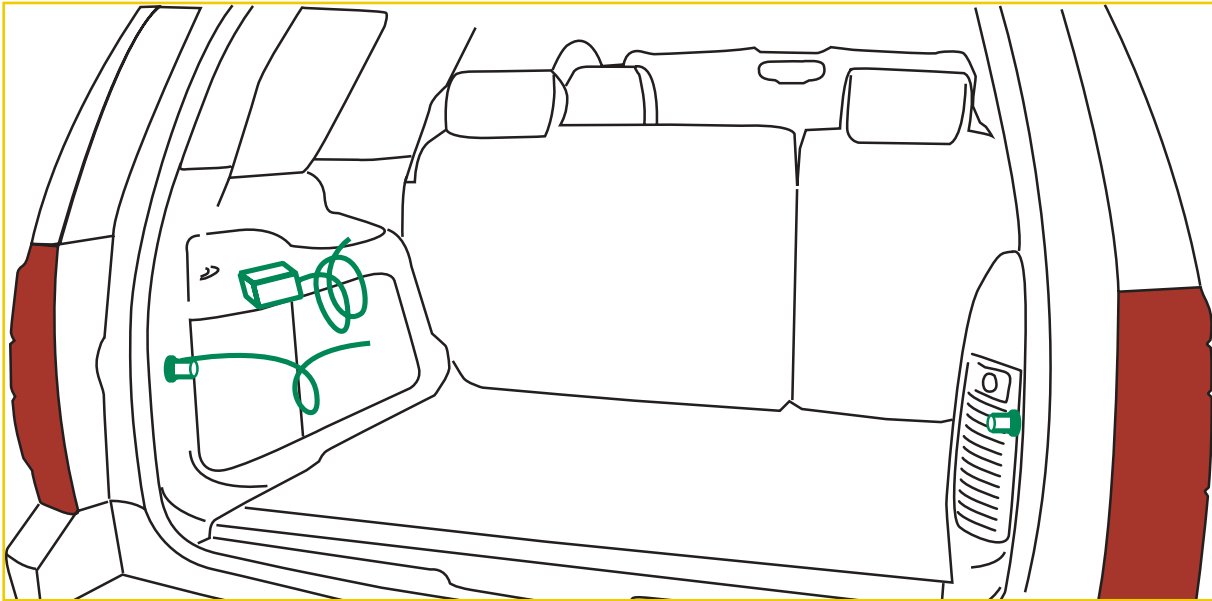

An auxiliary power junction block is located within the driver's side rear cargo area jack stowage compartment. This junction block is split to provide two circuits for connection to customer-furnished equipment directly to the battery through separate 50 amp circuit breakers. These circuit breakers are located in the breaker/relay panel forward of the instrument panel glove box. A maximum load of 100 amps (1,200 watts) can be connected.

This junction block is connected to a coiled 5-foot (1.5 m) branch of rear body harness and fastened near the jack. Mounting of the junction block can be at customer-selected rear cargo area locations permitted by the branch harness length and using customer-furnished mounting hardware.

The junction block should not be attached to the interior trim plastic components without appropriate backing hardware to the mounting bolts.

Grounding studs are located on the left and right sides of the lift-gate opening. See page 43.

WIRING

Tahoe

WIRING PROVISION FOR VEHICLE GRILLE LAMPS, FLASHER, AND SPEAKER/SIREN - SEO 6J3

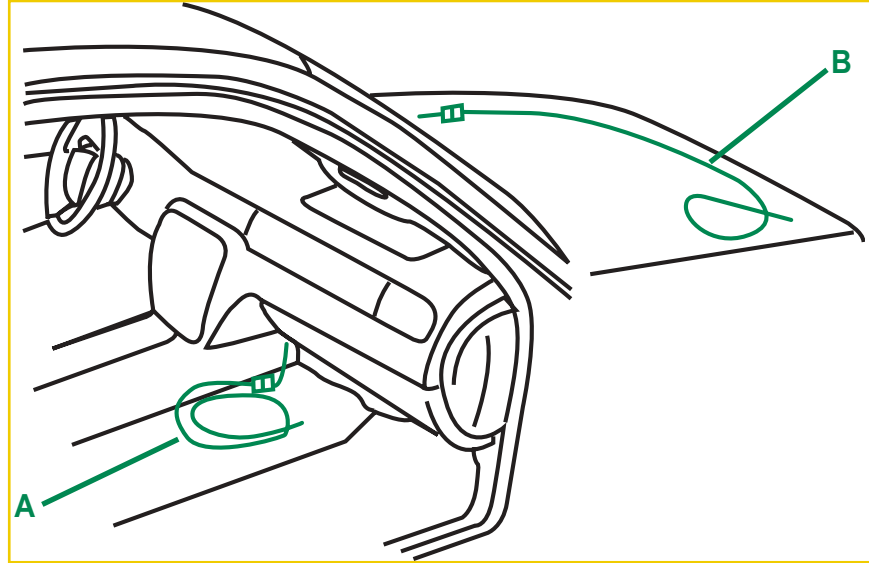

- A. Blunt cut ends for the Alternating Signal Flasher, Customer-Furnished Grille Lamps and Customer-Furnished Siren/Speaker
- B. Control Wires from In-Line Connector in Forward Lamp Harness for Customer-Furnished Grille Lamps and Speaker

This wiring provision option consists off one 16 gauge (1.0 mm) wire connected to an alternating signal flasher located underneath the instrument panel on the passenger's side. Five feet (1.5 m) of extra wire from the flasher is routed from underneath the instrument panel to an area behind the grille. All four wires have 12 inches (30 cm) of extra wire in a coil behind the grille. Grille lamps and the speaker are not included. The flasher is not included when SEO 6J7 is ordered without SEO 6J3.

The SEO 6J3 wiring provision also includes control wiring for the SEO 6J7 exterior lamps emergency flashing system. A dark green/red 18 gauge (0.8 mm²) headlamps flasher module control wire activates the flashing system when 12-volts are applied.

When SEO 6J7 is installed without SEO 6J3, only the dark green red control wire is proved for connection to customer-furnished 12-volt switching to turn the emergency flashing system on or off.

WIRING DIAGRAM FOR SEO 6J3 AND SEO 6J7

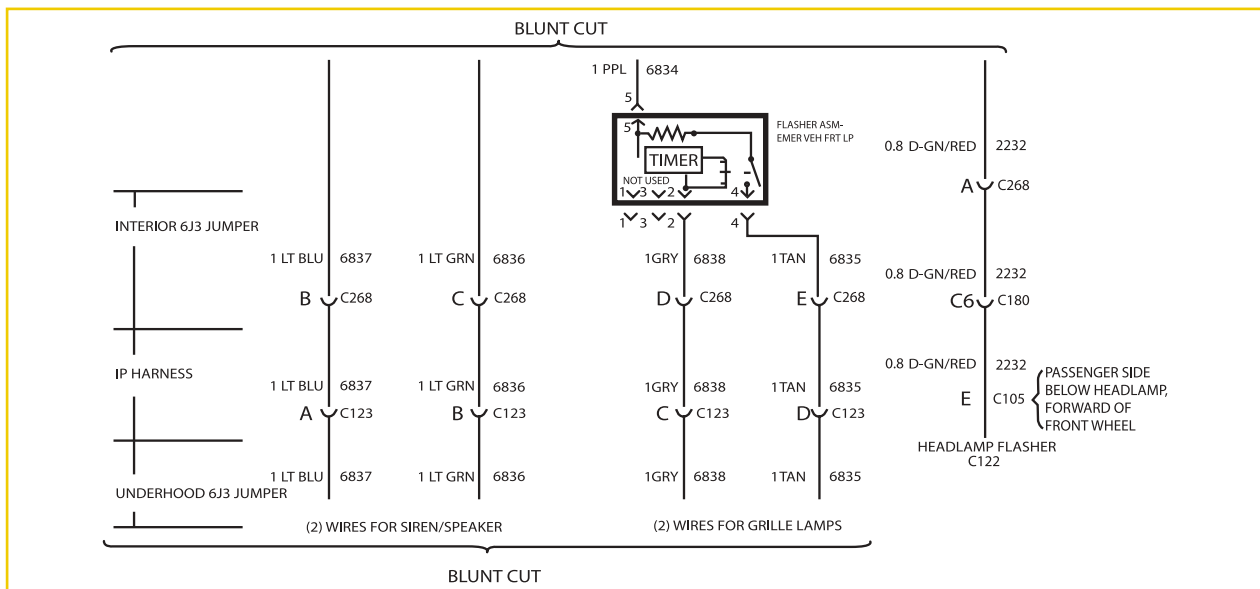

WIRING

Tahoe

EXTERIOR LAMP EMERGENCY FLASHING SYSTEM - SEO 6J7

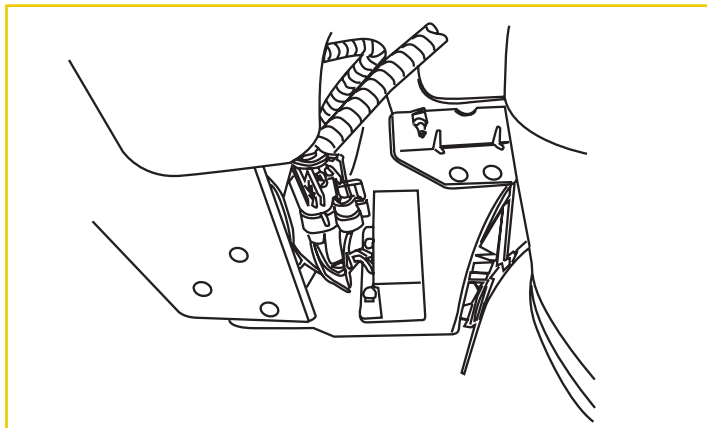

SEO 6J7 provides a high-beam headlamps flashing module, rear lamps flashing control wire for a customer-furnished switch, to turn the module on or off. The flasher control wire is coiled under the center of the instrument panel. This control lead may be combined with the interior wiring leads for SEO 6J3 when that option is ordered with SEO 6J7.

The headlamps flashing module is located below the passenger's side front headlamp and forward of the passenger's side front wheel. The module is connected to an inline connector in the forward lamp harness. The headlamps flashing module is activated by the application of 12 volts to a dark green/red wire coiled in the passenger's side footwell. When activated, the driver's and passenger's side high-beam headlamps and the high-beam instrument panel cluster light will flash alternately at 2.4 flashes per second.

When the headlamps flashing module is turned on, the module sends a signal to the Body Control Module (BCM). The BCM alternately flashes the stop lamps and backup lamps. Depressing the brake pedal will override the stop lamp flashing and placing the transmission in reverse will override the backup lamp flashing.

Activation of the headlamp and rearlamp flashing can be separated. Call Kerr Industries at 905-725-6561 for instructions.

During daylight conditions, the Daytime Running Lamps (DRL) are automatically turned off whenever the headlamps flashing module is activated. During nighttime conditions, the low-beam headlamps turn on automatically while the high-beam headlamps flash. Turning on the high-beam headlamps manually with the turn signal/multifunction lever will override the flashing module and the high-beam headlamps will operate continuously.

A 20-amp fuse protects the flasher module circuit. This fuse is located in the underhood fuse block in the engine compartment on the driver's side of the vehicle. See "Fuses and Circuit Breakers" in the Service and Appearance Care section of your Tahoe owner's manual for more information.

When it is dark outside, the tail lamps will turn on automatically. The Center High-Mounted Stoplamp (CHMSL) will not flash and will operate only when the regular brake pedal is pressed.

FORWARD LAMP HARNESS IN-LINE CONNECTOR FOR USE WITH HEADLAMPS FLASHER MODULE, OPTION 6J7

				C122
GROUND	250	0.8 BLK	A	
LH HI BEAM	711	0.35 D-GN/WH	B	B 711 0.35 D-GN/WH
HDLP WASH	3640	0.8 RD/WH	C	
RH HDLP HI	311	0.5 L-GN/BK	D	D 311 0.5 L-GN/BK
CONTROL	6820	0.35 D-GN/RD	E	
BCM	6841	0.5 D-BU/YE	F	

* FUSE BLOCK, UNDERHOOD

WIRING

Tahoe

WIRING PROVISIONS FOR EMERGENCY VEHICLE ROOF LIGHT - SEO TRW

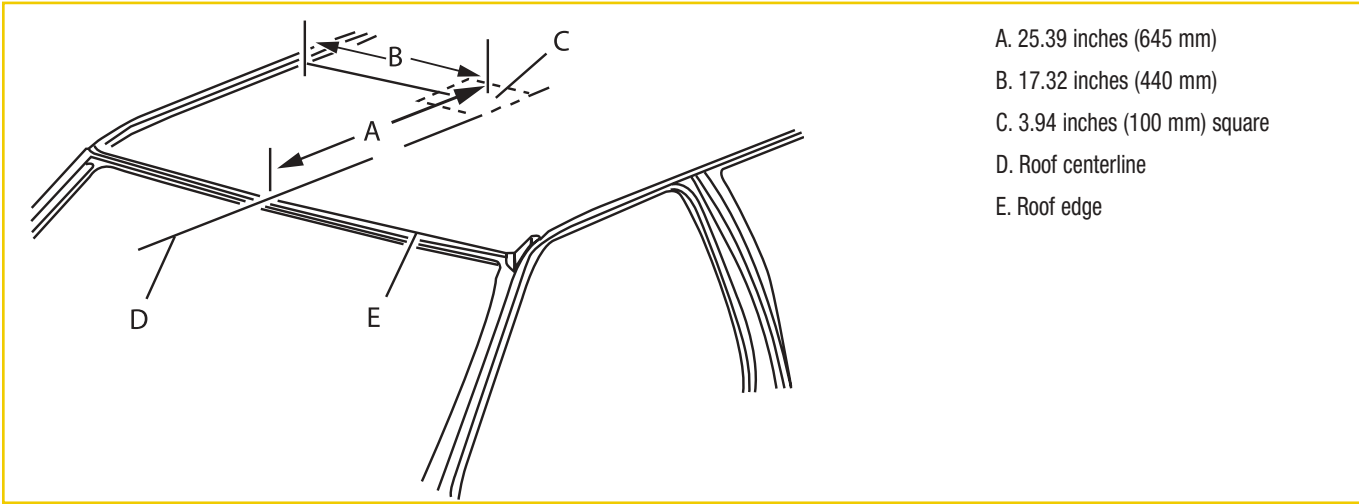

Batter power is supplied through a 30-amp fuse to a wiring harness located in the roof. Power is controlled with a switch located in the overhead console. The customer or vehicle upfitter must complete the installation to an added accessory such as an emergency beacon lamp.

Maximum rated electrical load is 21 amps (250 watts). The added electrical requirements must not exceed 21 amps (250 watts). Running the accessory for long periods of time with the engine off may run the battery down.

WIRING DIAGRAM FOR SEO TRW EMERGENCY ROOF LIGHT

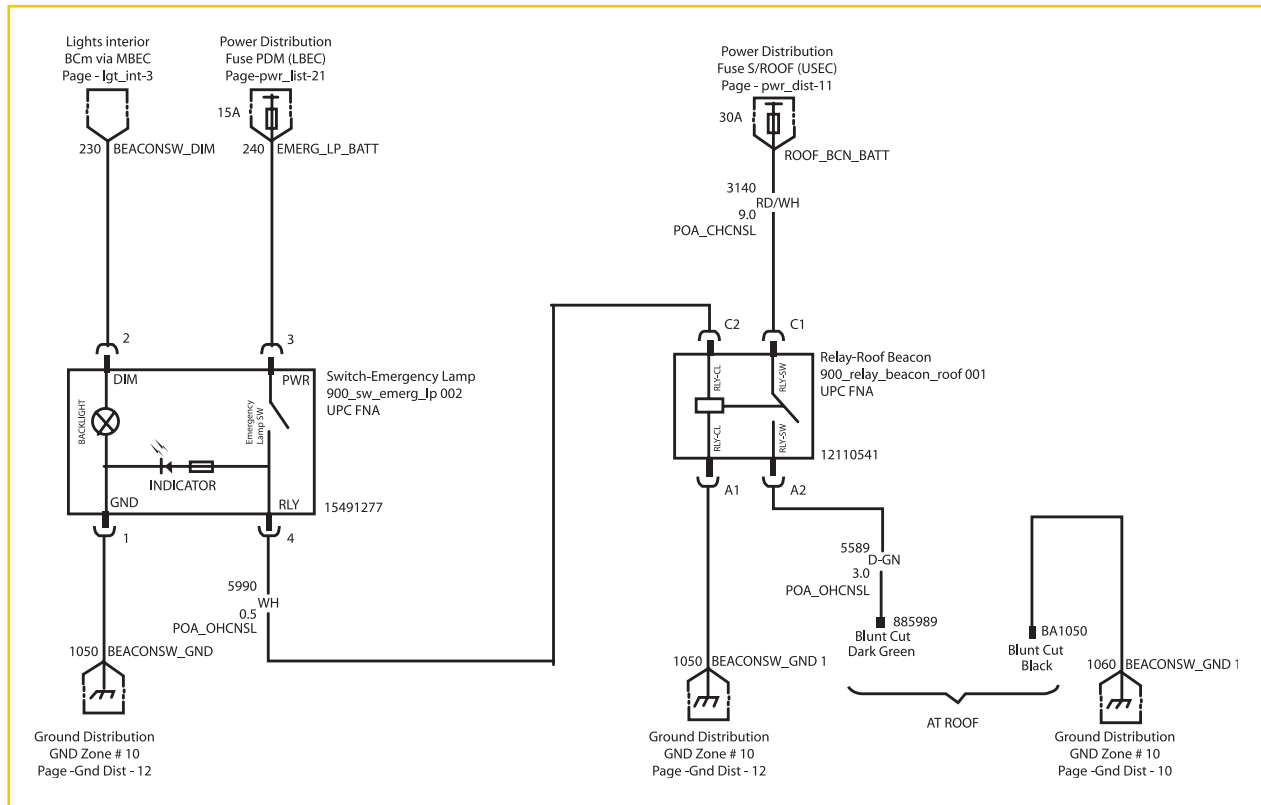

WIRING

Tahoe

WIRING PROVISIONS FOR FRONT SPEAKER - SEO WX7

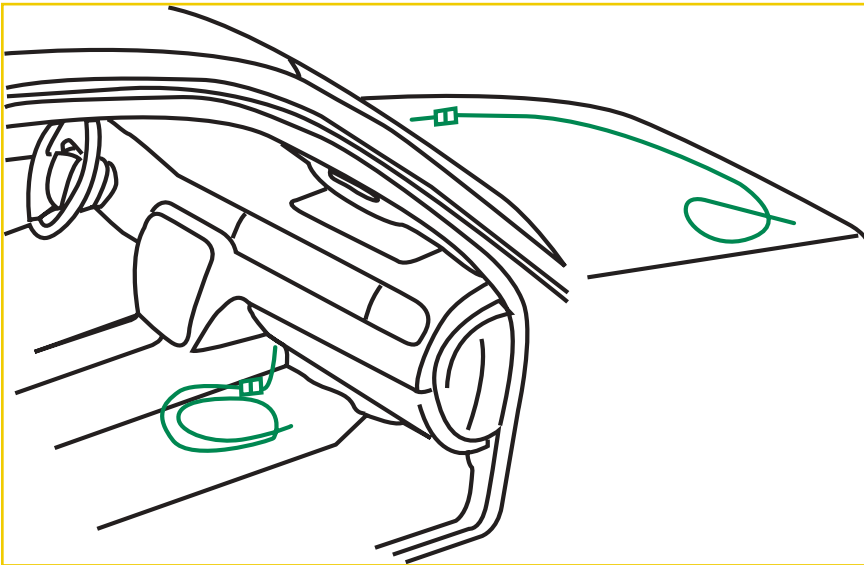

About 65 inches (165 cm) of auxiliary speaker wire is run from the instrument panel radio connector and is coiled under the center of the instrument panel. The wiring permits the connection of front door speakers to customer-installed communication equipment.

Radio outputs from the front speakers are sent to the rear speakers to maintain the required open door/key in the ignition reminder chime.

WIRING DIAGRAM FOR SEO WX7 INLINE CONNECTOR

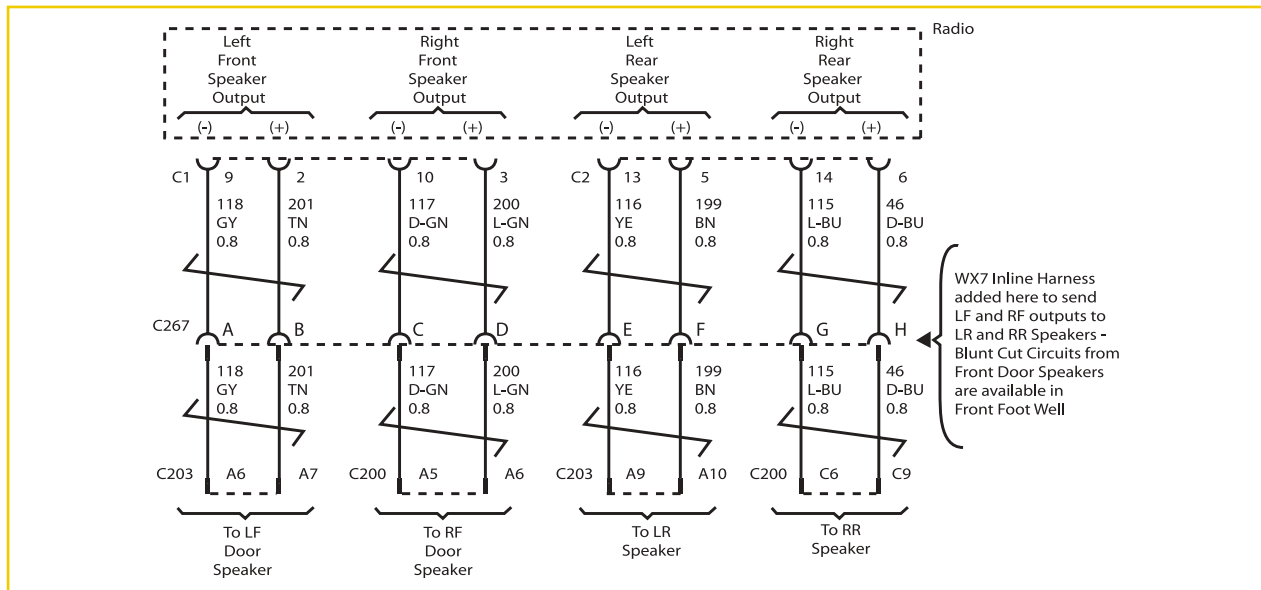



Fleet and Commercial

For Information 1-800-FLEET-OP (353-3867)
www.gmfleet.com