

28. POLICE COMPONENT LOCATION GUIDE

OPTIONAL EQUIPMENT INFORMATION ..	28-2	AMP STAY	28-10
CIRCUIT SCHEMATIC.....	28-3	LOWER COWL	28-11
HOW THE CIRCUITS WORK	28-4	MIRROR COVER	28-12
CONNECTIVITY/INSTALLATION	28-5	MIDDLE COWL	28-13
BODY PANEL LOCATIONS	28-7	RIGHT HANDLEBAR SWITCH TROUBLESHOOTING.....	28-16
TRIM CLIPS	28-8	SIREN CIRCUIT TROUBLESHOOTING	28-17
SINGLE SEAT COWL.....	28-8	STROBE CIRCUIT TROUBLSHOOTING	28-19
SEAT.....	28-9	COMPONENT LOCATION PHOTOGRAPHS	28-23
SADDLEBAG	28-9		
SIDE COVER.....	28-10		

POLICE COMPONENT LOCATION GUIDE

OPTIONAL EQUIPMENT INFORMATION

The addition of components and equipment at various locations of the motorcycle may impact handling and or stability. Whenever components or equipment are added to the motorcycle, a performance evaluation, by a qualified member of the police department, should be carried out to carefully assess the impact on vehicle handling. This evaluation should include all expected and anticipated service speeds and be conducted on a closed course environment prior to putting the vehicle into public service.

▲WARNING

- Improper accessories or modifications can cause a crash in which you can be seriously hurt or killed.
- Follow all instructions in this Service Manual regarding accessories and modifications.
- When installing any optional equipment, the allowable weight and power capacity must not be exceeded.

Equipment	Attachment	Allowable Weight kg (lbs)	Allowable Power
Right and left front strobe lamp	Right and left front stay	1.0 (2.2) x 2	-
Rear strobe lamp (including the pole and stay)	Rear cowl bracket	2.5 (5.5)	-
Siren speaker	Left engine guard	4.0 (8.8)	-
Strobe control unit	Amp stay	2.0 (4.4)	60 W
Siren control unit	Amp stay	1.5 (3.3)	60 W
Radio amplifier	Amp stay	6.0 (13.2)	-

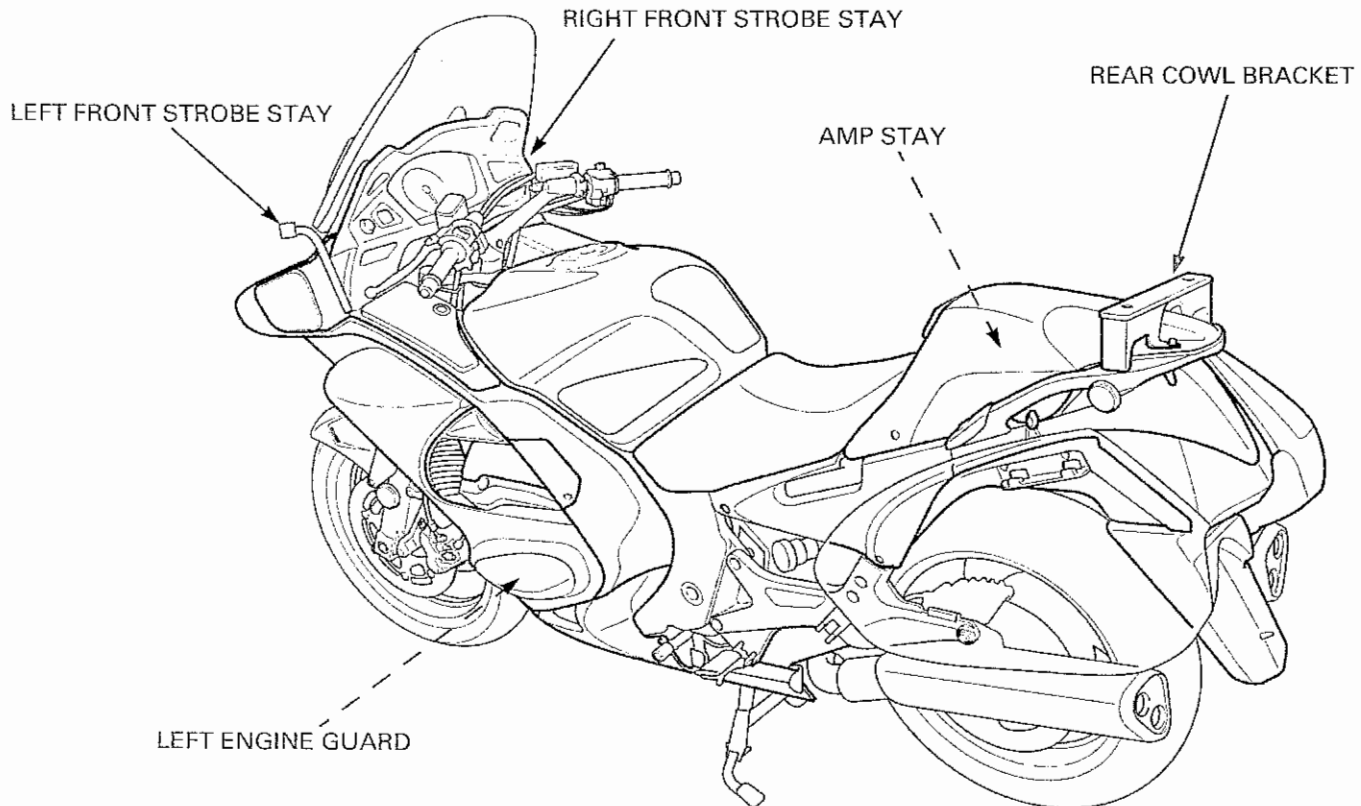

CIRCUIT SCHEMATIC

Refer to page 28-23 and 28-24 for photos.

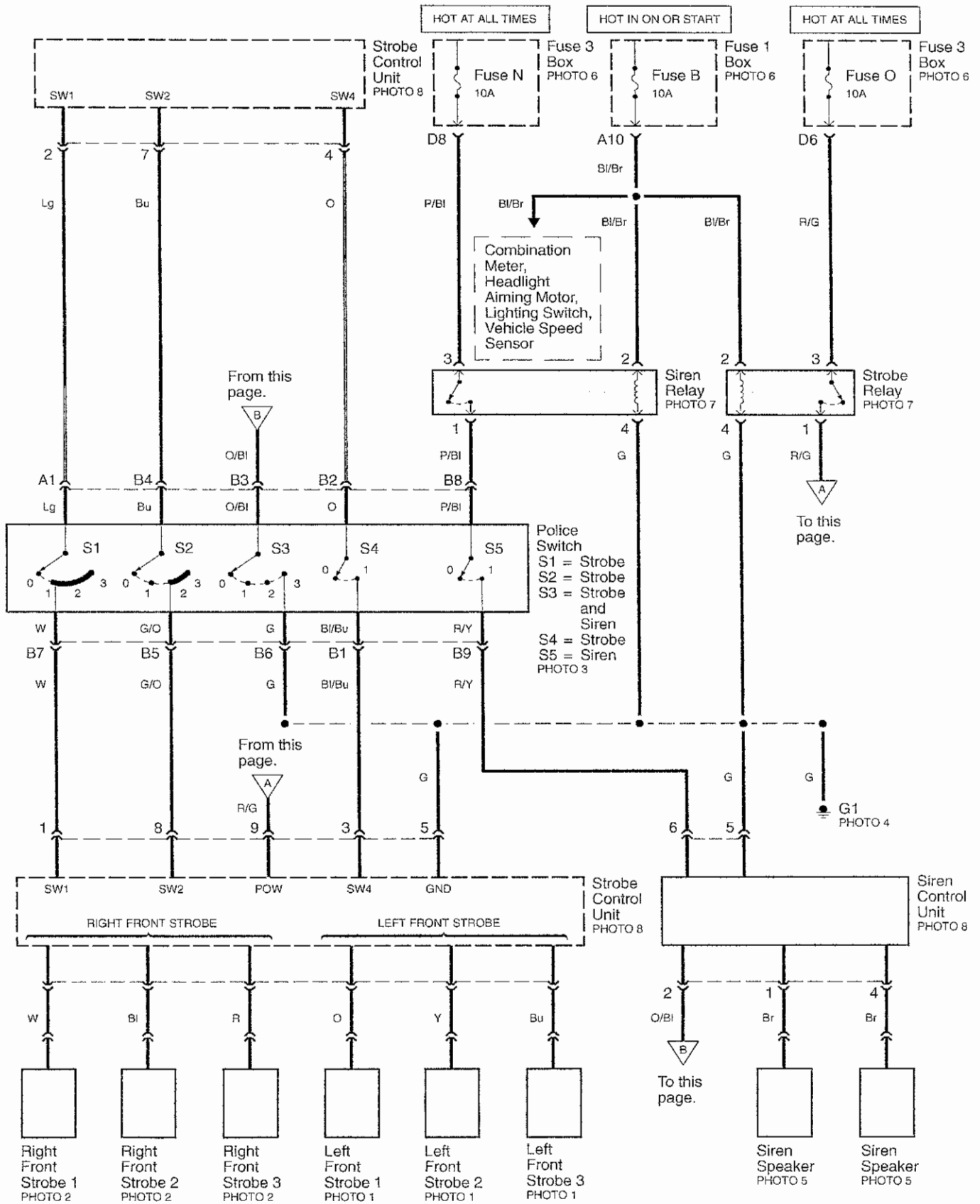

POLICE COMPONENT LOCATION GUIDE

HOW THE CIRCUITS WORK

GENERAL

The police equipment is composed of left and right strobe lights, police switches, siren speakers, strobe relay, siren relay, strobe control unit, and siren control unit.

With the ignition switch ON, battery voltage is applied through fuse B (in the fuse 1 box) to the coil of the strobe relay and siren relay which are grounded at G1. The coil of the relays is then energized which closes the relay contacts applying voltage through fuse N and O (in the fuse 3 box) and to the police switch pin B8 and strobe control unit pin 9.

POLICE SWITCHES

The right handlebar switch assembly contains three switches that control the strobes and siren. The "1, 2, 3" switch controls the strobes plus siren. The "4" switch controls the strobes only. The "5" switch controls the siren only. The "1, 2, 3" switch controls the strobes only when it is set to position 1 and 2, and adds siren to the strobes when in position 3.

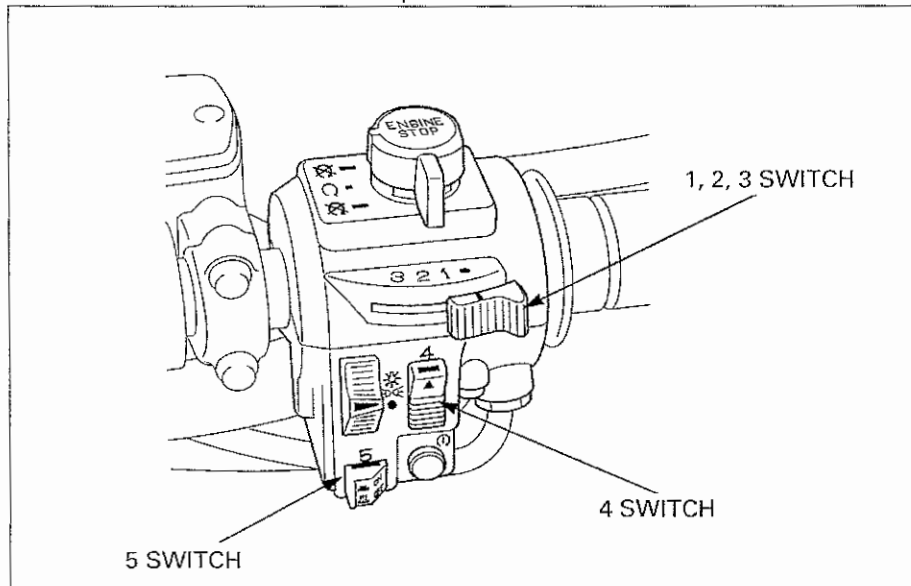

SIREN

The siren is primarily controlled by the "5" switch located on the right handlebar. When the "5" switch is pushed in, battery voltage from pin B9 is applied to the siren control unit at pin 6, which then turns on the siren. When the "1, 2, 3" switch on the right handlebar is in the 3 position, the siren is added to the strobe.

STROBE

The strobes are controlled by the "1, 2, 3" switch and the "4" switch located on the right handlebar. Signals from the "1, 2, 3" switch position 1 (pin B7), position 2 (pin B5), and the "4" switch (pin B1) are applied to the strobe control unit, which then turns on the strobes.

CONNECTIVITY/INSTALLATION

SIREN CONTROL UNIT

Remove the single seat cowl (page 28-8).

Remove the amp stay (page 28-10).

Refer to the siren control unit manufacturer's instructions; install and connect the siren control unit to the 6P (Black) connector.

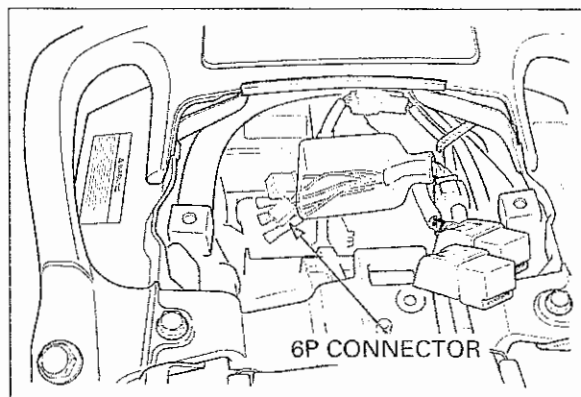

STROBE CONTROL UNIT

Remove the single seat cowl (page 28-8).

Remove the amp stay (page 28-10).

Refer to the strobe control unit manufacturer's instructions; install and connect the strobe control unit to the 9P (Green) connector and the six 1P connectors as follows:

Connection:

9P (Green)	-input to the control unit
1P (Orange, Yellow, Blue)	-output to the left strobe
1P (White, Black, Red)	-output to the right strobe

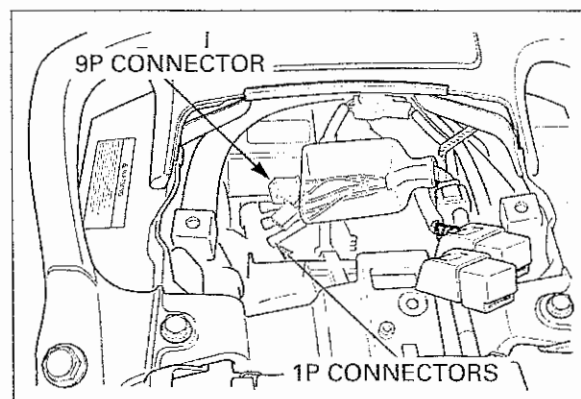

SIREN

Remove the left middle cowl (page 28-14).

Locate the two siren 1P (Brown) connectors inside the connector boot.

Refer to the siren manufacturer's instructions; install the siren connectors.

Install the left middle cowl (page 28-14).

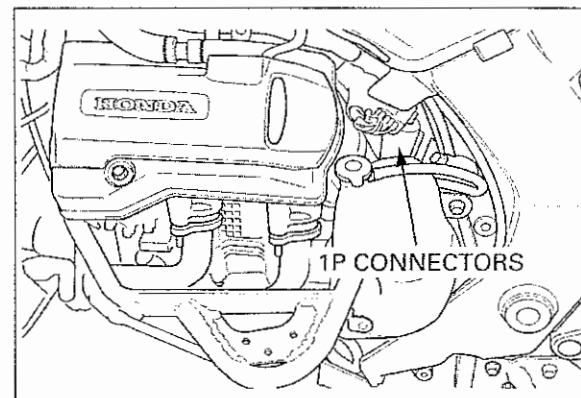

POLICE COMPONENT LOCATION GUIDE

The siren can also be installed on the right engine guard, which requires removal of the right engine guard cover.

Refer to the siren manufacturer's instructions; install the siren onto the left engine guard.
Install the engine guard cover (page 28-13).

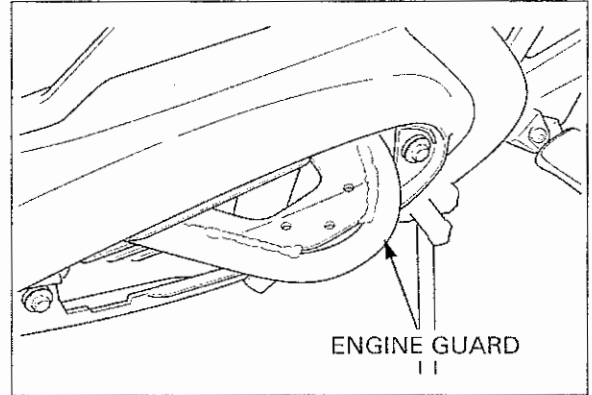

STROBE

Remove the left and right mirror covers (page 28-12).

Refer to the strobe manufacturer's instructions; connect the left strobe to the 1P (Orange, Yellow, Blue) connectors.

Refer to the strobe manufacturer's instructions; connect the right strobe to the 1P (White, Black, Red) connectors.

Refer to the strobe manufacturer's instructions; install the left and right strobes onto the strobe stays.

Install the left and right mirror covers (page 28-12).

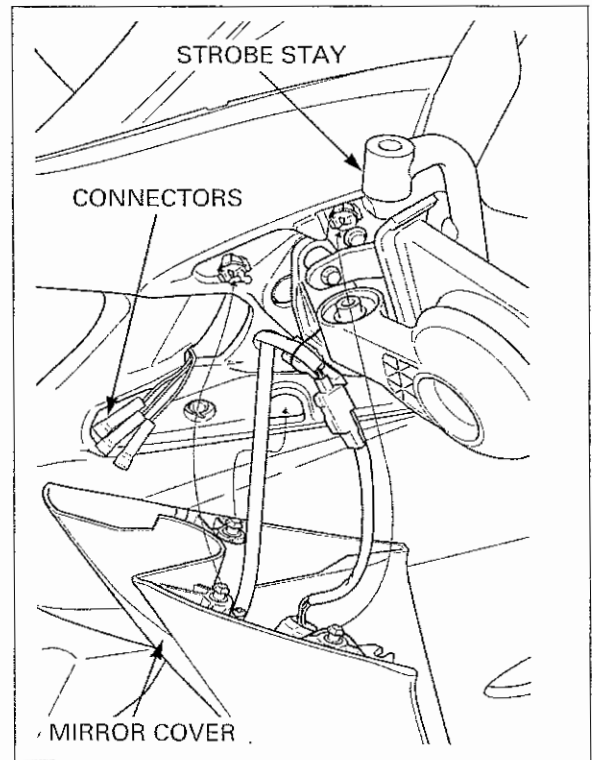

BODY PANEL LOCATIONS

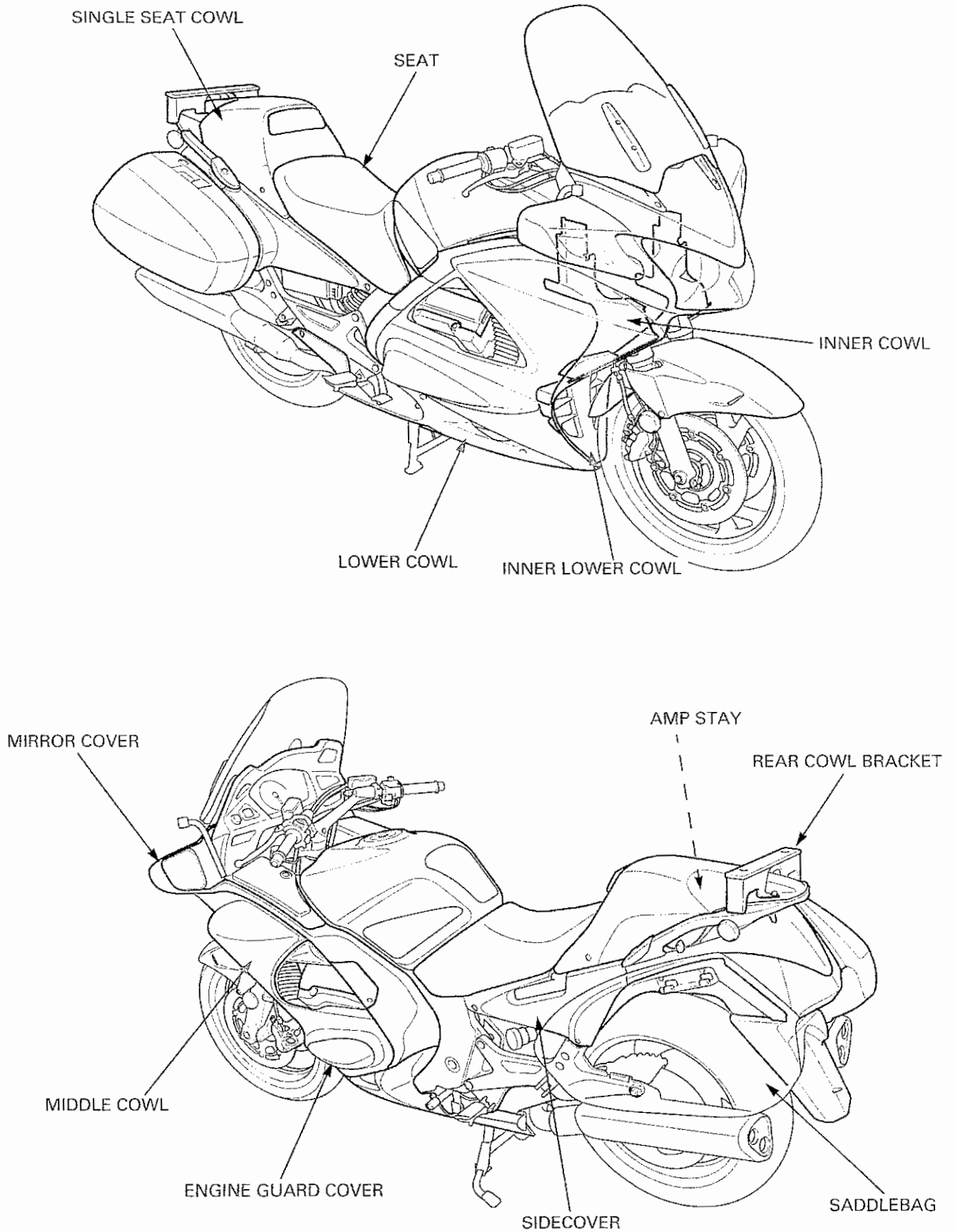

POLICE COMPONENT LOCATION GUIDE

TRIM CLIPS

REMOVAL

Push the center of the trim clip pin.

Remove the trim clip.

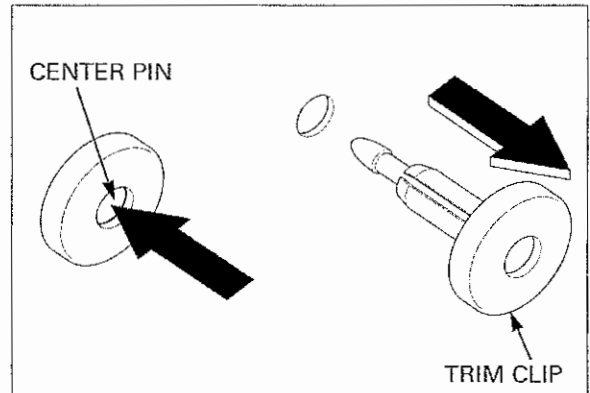

INSTALLATION

Raise the center pin by pushing the center pin back.

Install the trim clip.

Push the center pin until the pin is flush with the outer casing.

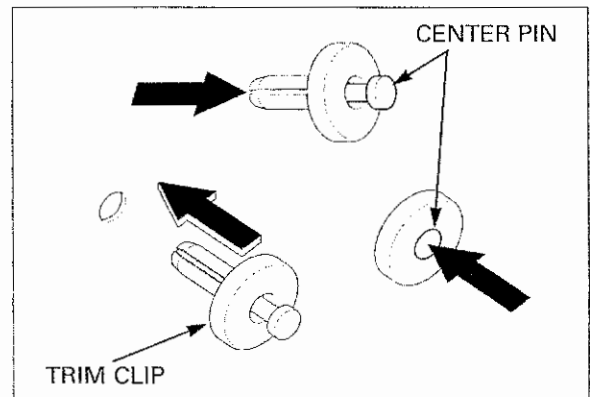

SINGLE SEAT COWL

Remove the bolts, cap nuts, collars and rear cowl bracket.

Remove the socket bolts, single seat cowl.

Installation is in the reverse order of removal.

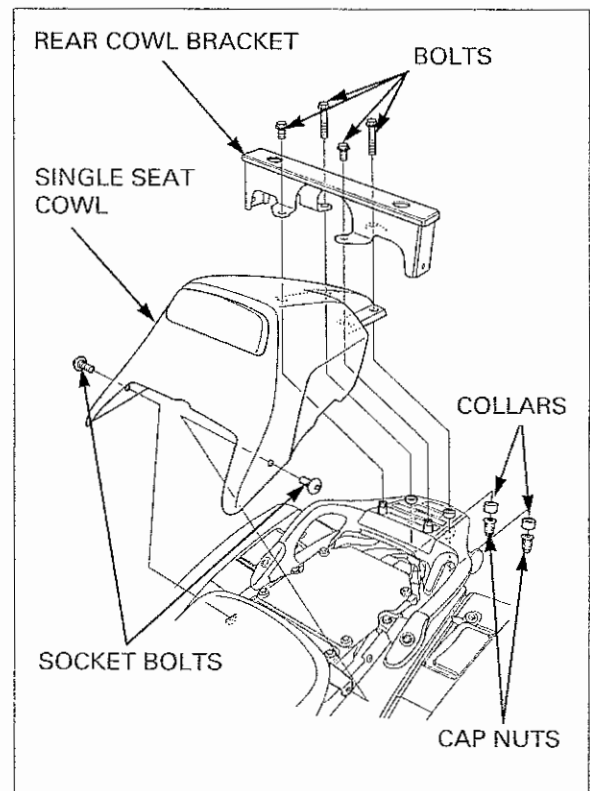

SEAT

Remove the single seat cowl (page 28-8).
Remove the bolt and seat.
Installation is in the reverse order of removal.

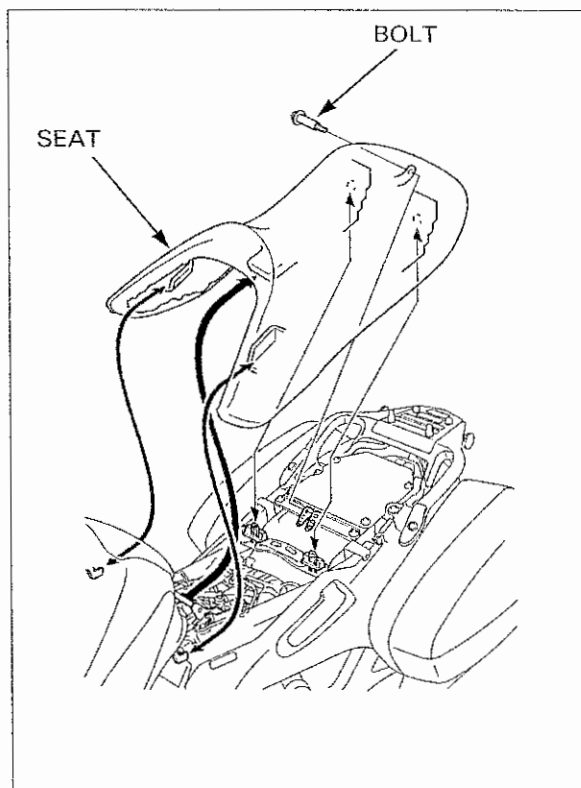

SADDLEBAG

Unlock the saddlebag lock lever with the ignition key.
Remove the saddlebag.

Align the hook on the saddlebag to the step holder.
Install the saddlebag aligning the holes on the saddlebag to the tabs on the saddlebag lock bracket by pushing down the saddlebag.
Lock the saddlebag lock lever with the ignition key.

After installation, check the installation of the saddlebag hook and step holder.

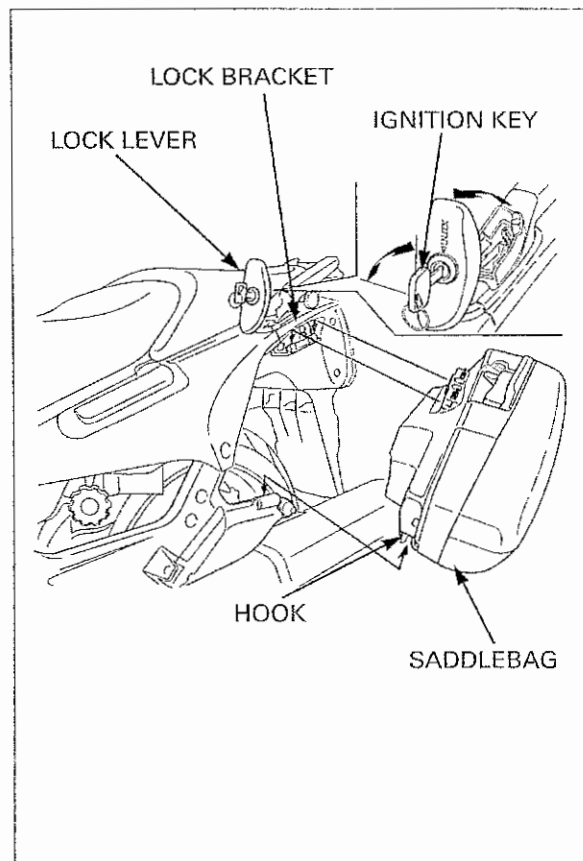

POLICE COMPONENT LOCATION GUIDE

SIDE COVER

Remove the seat (page 28-9).

Remove the three socket bolts (5 mm and 6 mm).

On the left side cover, pull the center stand grip when removing the cover.

Release the boss from the grommet being careful not to damage the tab, then remove the side cover.

Installation is in the reverse order of removal.

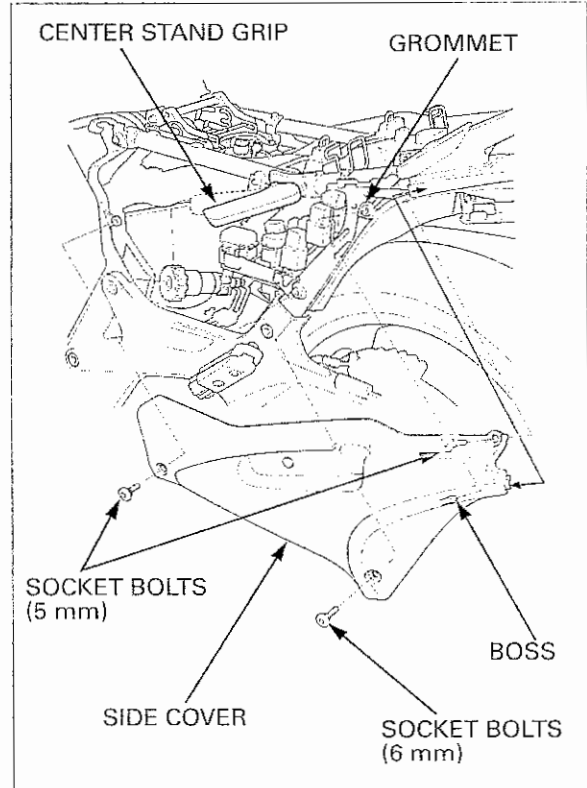

AMP STAY

Remove the single seat cowl (page 28-8).

Remove the two relays from the amp stay.

Remove the four bolts and the amp stay.

Installation is in the reverse order of removal.

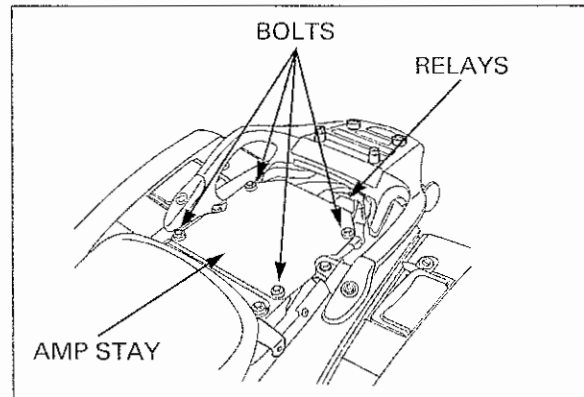

LOWER COWL

INNER LOWER COWL

Remove the two screws and two trim clips.
Remove the inner lower cowl.

Installation is in the reverse order of removal.

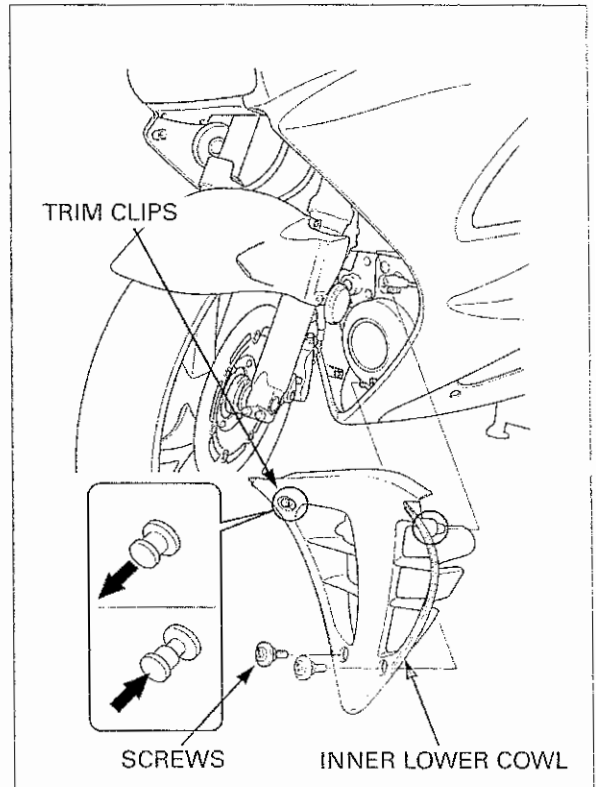

LOWER COWL

REMOVAL/INSTALLATION

Remove the ten socket bolts and three trim clips.
Remove the lower cowl.

Installation is in the reverse order of removal.

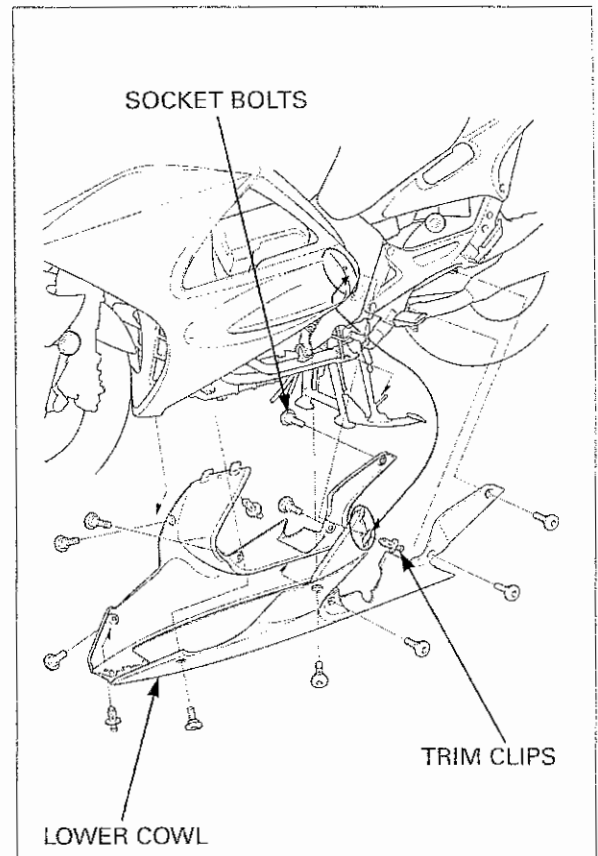

POLICE COMPONENT LOCATION GUIDE

DISASSEMBLY/ASSEMBLY

Remove the lower cowl (page 28-11).

Remove the two trim clips and disassemble the right lower cowl and left lower cowl.

Assembly is in the reverse order of disassembly.

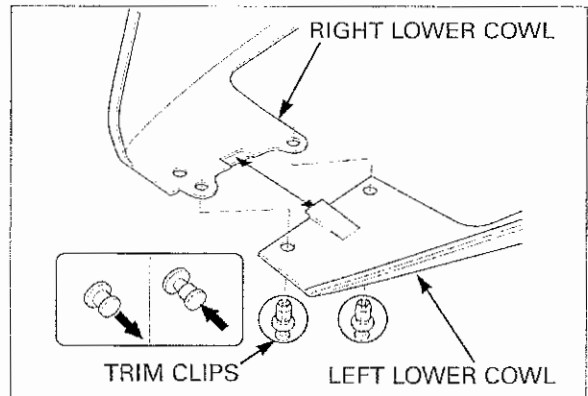

MIRROR COVER

MIRROR COVER

Remove the mirror cover by carefully releasing the three bosses from the clips of the upper cowl.

Installation is in the reverse order of removal.

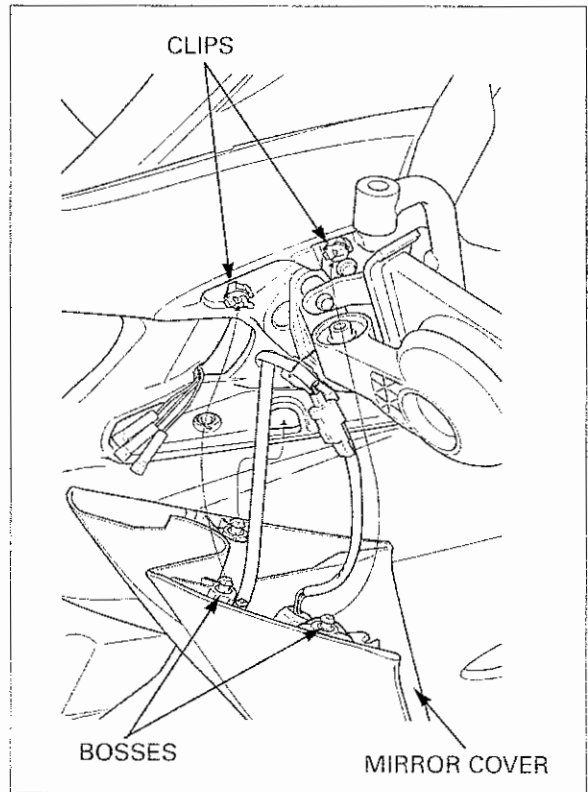

MIDDLE COWL

ENGINE GUARD COVER

Remove the socket bolt.
Release the five tabs on the engine guard cover from the grooves on the middle cowl and remove the engine guard cover.

Install the front tab on the engine guard cover to the middle cowl, then install the four tabs to the middle cowl.

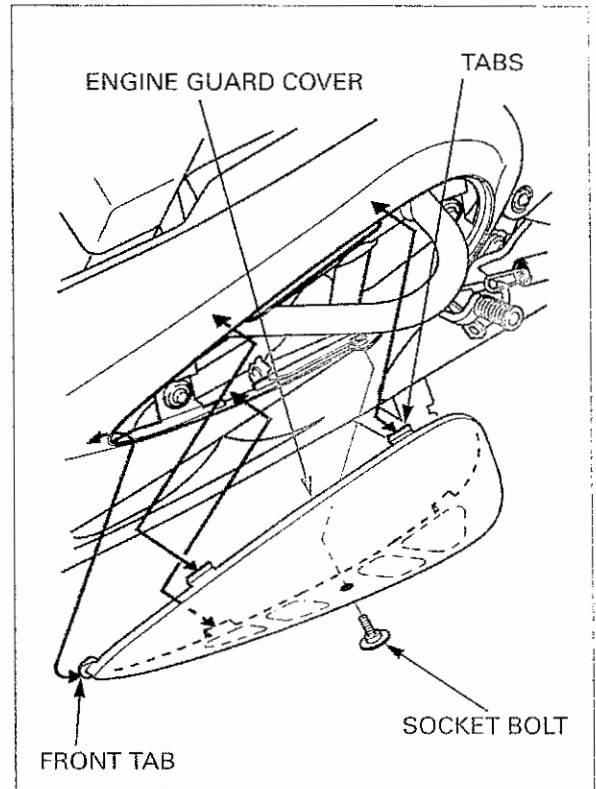

INNER COWL

Remove the two trim clips.
Remove the four trim clips and one screw.
Remove the inner cowl.

Right side only: Disconnect the open air temperature sensor 2P connector.

Installation is in the reverse order of removal.

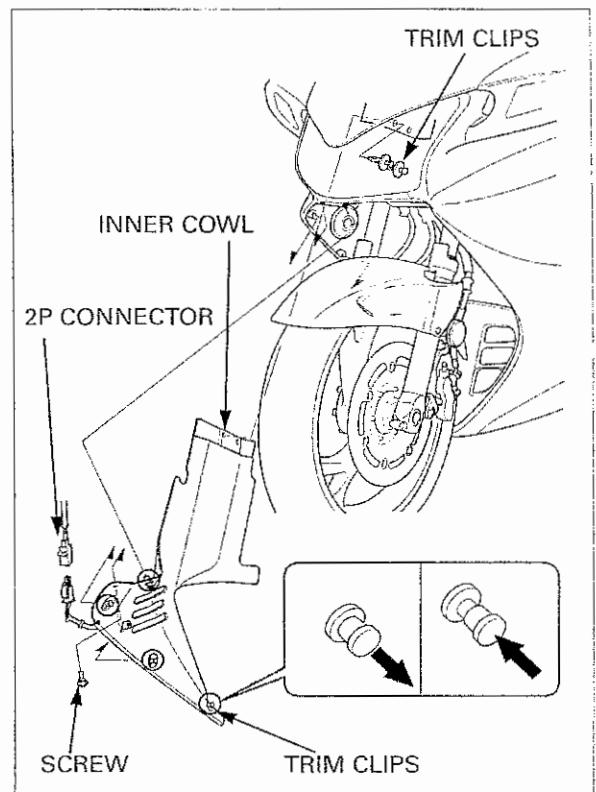

POLICE COMPONENT LOCATION GUIDE

MIDDLE COWL

REMOVAL/INSTALLATION

Remove the following:

- Remove the mirror cover (page 28-12)
- Remove the lower cowl (page 28-11)
- Remove the inner cowl (page 28-13)

Remove the two middle cowl bolts, collars and one socket bolt.

Remove the four screws, trim clip, then remove the middle cowl.

Left side only: Remove the sub-harness 24P (White) connector from the groove on the left cowl pocket.

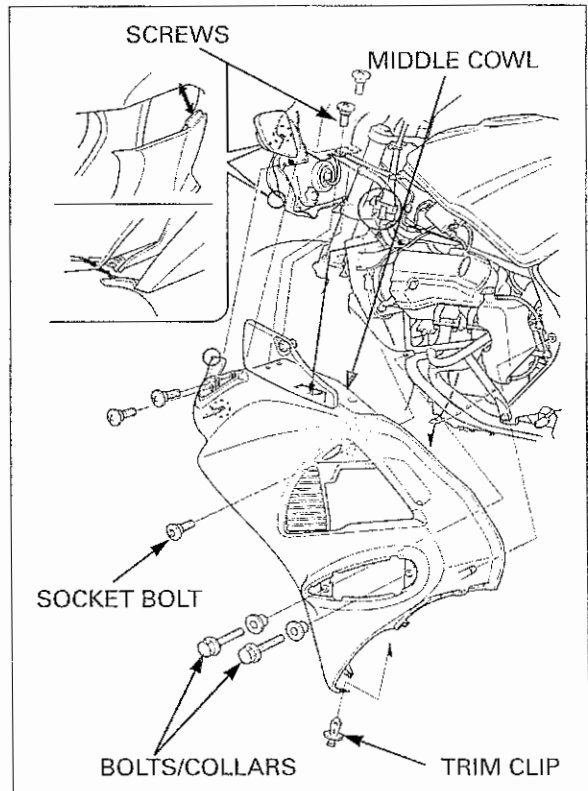

Install the middle cowl aligning the tabs on the middle cowl with the grooves on the upper cowl and tab on the middle cowl with the grommet on the engine guard.

Installation is in the reverse order of removal. Install the new middle cowl bolts to the specified torque.

TORQUE: 10 N·m (1.0 kgf·m, 7 lbf·ft)

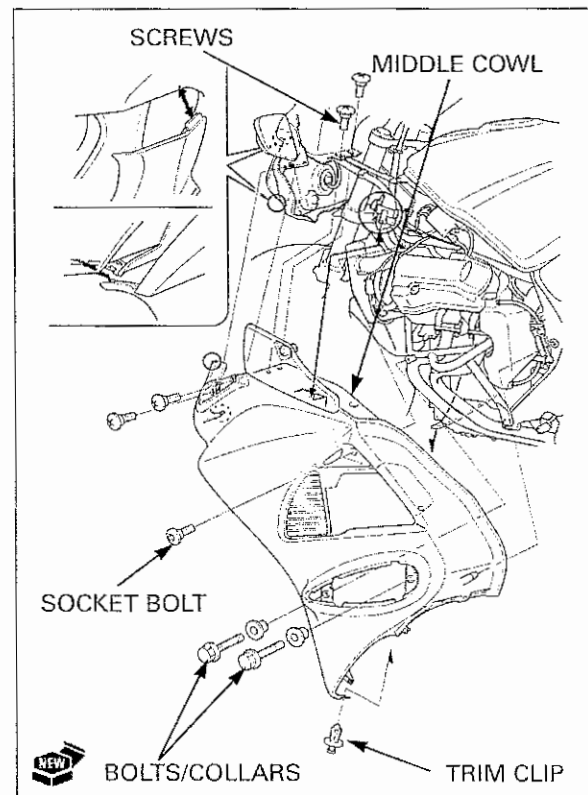

POLICE COMPONENT LOCATION GUIDE

Check that the middle cowl lip covers the heat guard mat of the fuel tank as shown.

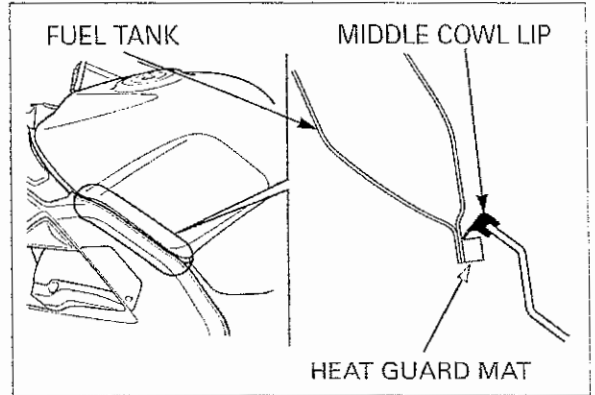

POLICE COMPONENT LOCATION GUIDE

RIGHT HANDLEBAR SWITCH TROUBLESHOOTING

Remove the right middle cowl (page 28-13).

Disconnect the right handlebar switch 1P (Natural) and 9P (Green) connectors.

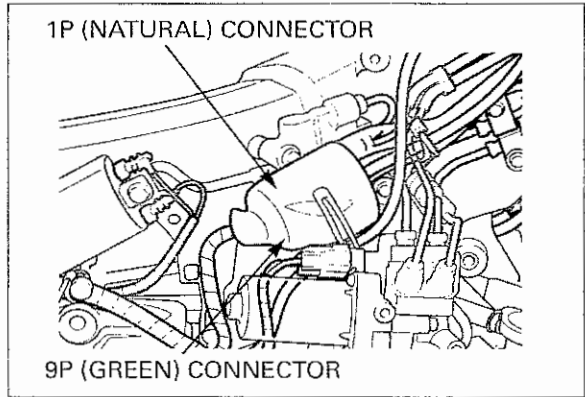

Check for continuity between the wire terminals of the handlebar switch connector. Continuity should exist between the color coded wire terminals as follows:

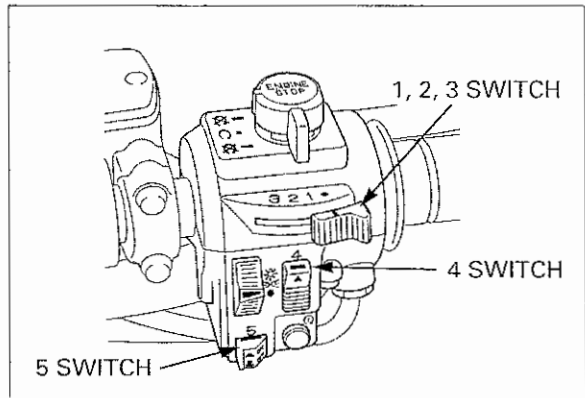

1, 2, 3/4/5 SWITCHES

1, 2, 3 SWITCH

	A1	B7	B4	B5	B3	B6
1	○	○				
2	○	○	○	○		
3	○	○	○	○	○	○
COLOR	Lg	W	Bu	G/O	O/B1	G

4 SWITCH

	B2	B1
OFF		
ON	○	○
COLOR	O	B1/Bu

5 SWITCH

	B9	B8
OFF		
ON	○	○
COLOR	R/Y	P/B1

SIREN CIRCUIT TROUBLESHOOTING

HOW THE SIREN WORKS

With the ignition switch ON, battery voltage is provided through fuse B (in the fuse 1 box) to the coil of the siren relay, which is grounded at G1. The coil of the relay is then energized, which closes the relay contact providing voltage through fuse N (in the fuse 3 box) and to the police switch pin B8.

When the "5" switch is pushed in, battery voltage from pin B9 is provided to the siren control unit pin 6.

A signal from the siren control unit pin 2 is applied to the police switch pin B3. When the "1, 2, 3" switch is held in the 3 position, the police switch pin B6 sends a ground signal to the strobe control unit pin 5 and siren control unit pin 5, which is grounded at G1.

The siren control unit pin 1 and pin 4, then sends a signal to the siren.

SIREN SYSTEM INSPECTION

1. Siren Operation Inspection

Turn the ignition switch ON and operate the siren for a few seconds.

Does the siren operate properly?

YES – No further testing is required.

NO – GO TO STEP 2.

2. Fuse N Inspection

Turn the ignition switch OFF and remove the siren relay.

Measure the voltage between the Pink/black (pin 3) of the wire harness side 4P connector and ground.

Is there battery voltage?

YES – GO TO STEP 3.

NO – Replace fuse N (10A) (page 28-23).

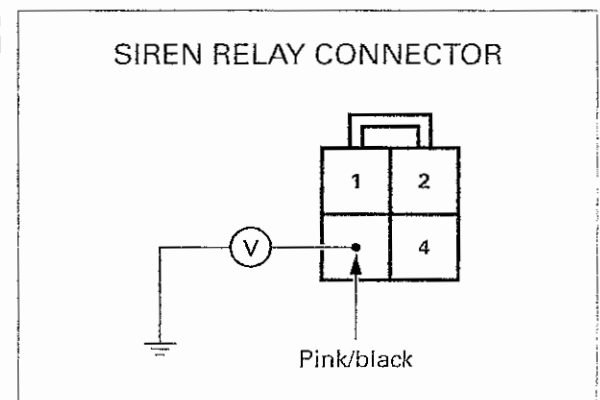
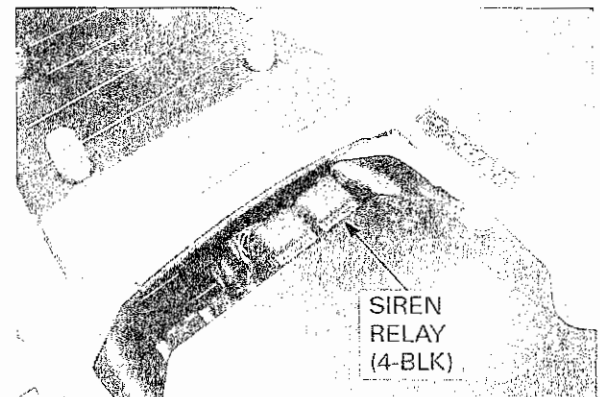

POLICE COMPONENT LOCATION GUIDE

3. Fuse B Inspection

With the siren relay still removed:
Turn the ignition switch ON.
Measure the voltage between the Blue/brown (pin 2) of the wire harness side 4P connector and ground.

Is there battery voltage?

YES – GO TO STEP 4.

NO – Replace fuse B (10A) (page 28-23).

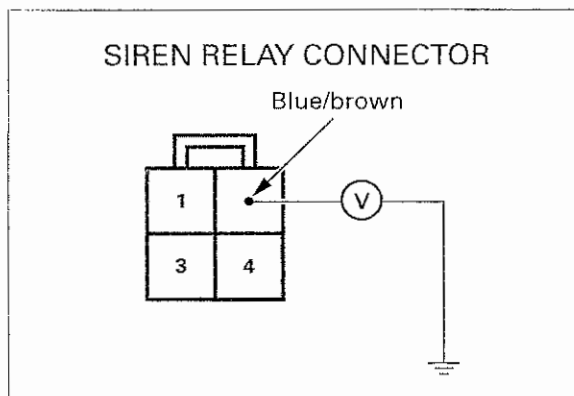

4. 1, 2, 3 Switch Continuity Inspection in position 3

Turn the ignition switch OFF.
Install the siren relay.
Disconnect the siren control unit 6P connector.
Place the "1, 2, 3" switch into position 3 (S3) and check for continuity between the Orange/blue (pin 2) and Green (pin 5) wire terminal of the siren control unit connector.

Is there continuity when the 1, 2, 3 switch is in position 3?

NO –

- Check for open circuit in the Orange/blue (pin 2) and Green (pin 5).
- Check for loose ground terminal.
- Check for loose contacts or corroded terminals at pin B3 and B6 of the "1, 2, 3" switch.
- Check the "1, 2, 3" switch continuity (page 28-16).

YES – GO TO STEP 5.

5. 5 Switch Continuity Inspection

Disconnect the siren relay 4P connector.
Check the "5" switch (S5) for continuity between the Red/yellow (pin 6) wire terminal of the siren control unit connector and the Pink/black (pin 1) wire terminal of the siren relay connector.

Is there continuity?

NO –

- Check for open circuit in the Red/yellow (pin 6) of the siren control unit connector and Pink/black (pin 1) of the siren relay connector.
- Check for loose contacts or corroded terminals at pin B8 and B9 of the 5 switch.
- Check the "5" switch continuity (page 28-16).

YES – GO TO STEP 6.

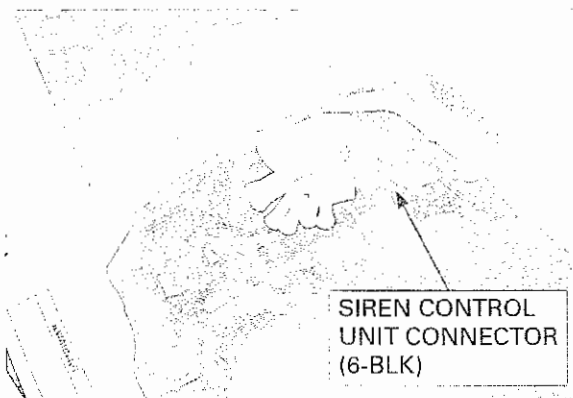

6. Siren Control Unit Inspection

Connect the siren relay 4P connector.
Turn the ignition switch ON.
Push in the "5" switch (S5).

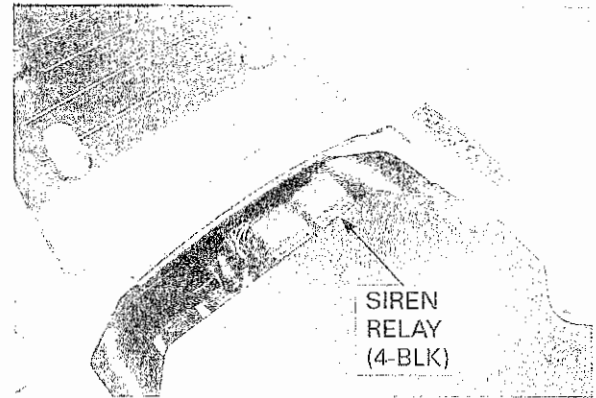

Measure the voltage between the Red/yellow (pin 6) of the wire harness side 6P connector and ground.

Is there battery voltage?

YES – Replace the siren control unit.

- NO** –
- Check for open circuit in the Red/yellow or Pink/black wire of the "5" switch.
 - Check the "5" switch continuity (page 28-16).

SIREN CONTROL UNIT CONNECTOR

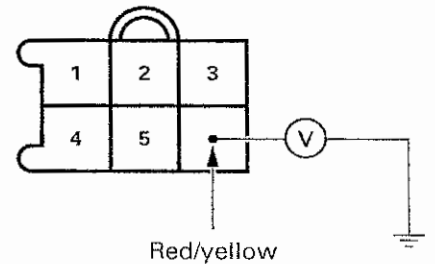

STROBE CIRCUIT TROUBLESHOOTING

HOW THE STROBE WORKS

With the ignition switch ON, battery voltage is provided through fuse B (in the fuse 1 box) to the coil of the strobe relay, which is grounded at G1. The coil of the relay is then energized, which closes the relay contact providing voltage through fuse O (in the fuse 3 box) and to the strobe control unit pin 9.

The "1, 2, 3" switch allows a different combination of strobes when set to position 1 or 2. The "4" switch controls the strobes independently of the "1, 2, 3" switch.

The strobe control unit controls the six 1-pin connectors. When the police switches are in position, the strobe control unit 1-pin connectors will supply power and ground to the left front and right front strobe lights.

POLICE COMPONENT LOCATION GUIDE

STROBE SYSTEM INSPECTION

1. Strobe Operation Inspection

Turn the ignition switch ON and operate the strobe for a few seconds.

Does the strobe operate properly?

YES – No further testing is required.

NO – GO TO STEP 2.

2. Fuse O Inspection

Turn the ignition switch OFF and remove the strobe relay.

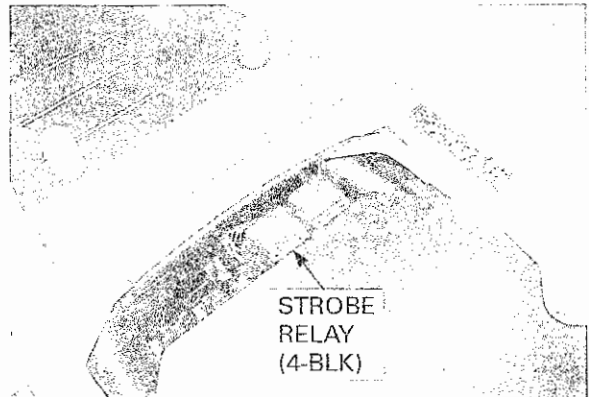

Measure the voltage between the Red/green (pin 3) of the wire harness side 4P connector and ground.

Is there battery voltage?

YES – GO TO STEP 3.

NO – Replace fuse O (10A) (page 28-23).

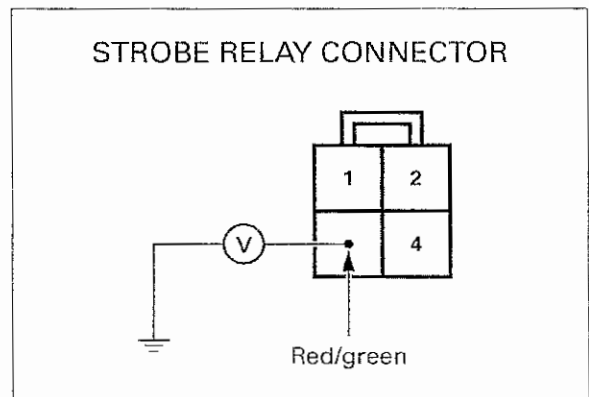

3. Fuse B Inspection

With the strobe relay still removed, turn the ignition switch ON.

Measure the voltage between the Blue/brown (pin 2) of the wire harness side 4P connector and ground.

Is there battery voltage?

YES – GO TO STEP 4.

NO – Replace Fuse B (10A) (page 28-23).

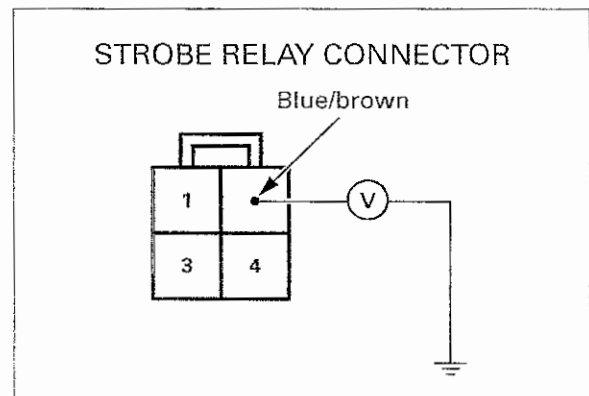

4. 1, 2, 3 Switch Continuity Inspection in position 1

Turn the ignition switch OFF.
Install the strobe relay.
Disconnect the strobe control unit 9P connector.
Place the "1, 2, 3" switch into position 1 (S1) and check for continuity between the White (pin 1) and Light Green (pin 2) wire terminals of the strobe control unit connector.

Is there continuity in position 1?

- NO** -
- Check for open circuit in the White (pin 1) and Light Green (pin 2).
 - Check for loose contacts or corroded terminals at pin A1 and B7 of the "1, 2, 3" switch.
 - Check the "1, 2, 3" switch continuity (page 28-16).

YES - GO TO STEP 5.

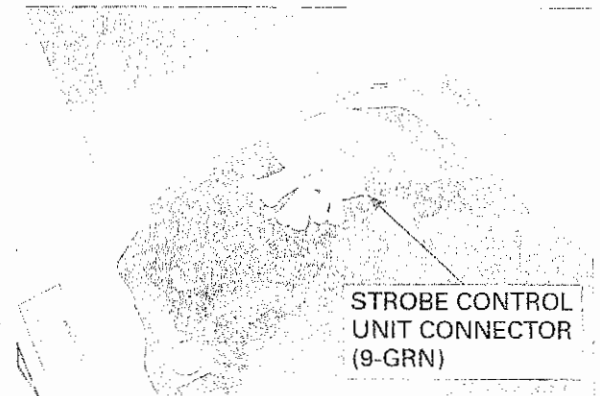

5. 1, 2, 3 Switch Continuity Inspection in position 2 and 3

Place the "1, 2, 3" switch into position 2 (S2) and check for continuity between the Blue (pin 7) and Blue/orange (pin 8) wire terminals of the strobe control unit connector.

Is there continuity in position 2 and 3?

- NO** -
- Check for open circuit in the Blue (pin 7) and Blue/orange (pin 8).
 - Check for loose contacts or corroded terminals at pin B4 and B5 of the "1, 2, 3" switch.
 - Check the "1, 2, 3" switch continuity (page 28-16).

YES - GO TO STEP 6.

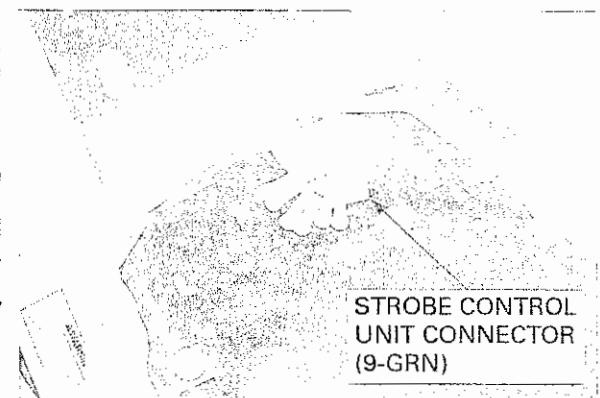

6. 4 Switch Continuity Inspection

Push in the "4" switch and check for continuity between the Black/blue (pin 3) and Orange (pin 4) wire terminals of the strobe control unit connector.

Is there continuity with the 4 switch pushed in?

- NO** -
- Check for open circuit in the Black/blue (pin 3) and Orange (pin 4) connector.
 - Check for loose contacts or corroded terminals at pin B1 and B2 of the "4" switch.
 - Check the "4" switch continuity (page 28-16).

YES - GO TO STEP 7.

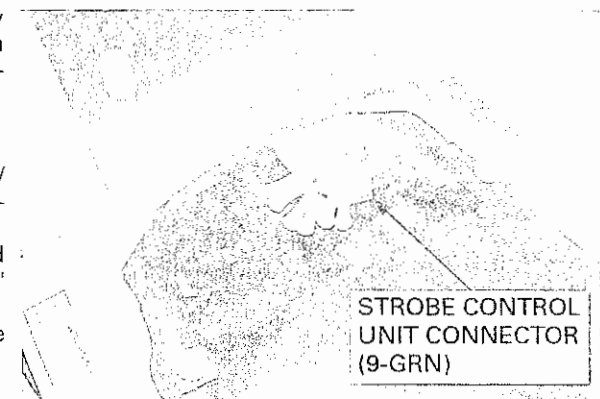

POLICE COMPONENT LOCATION GUIDE

7. Strobe Control Unit Inspection

Turn the ignition switch ON.

Measure the voltage between the Red/green (pin 9) of the wire harness side 9P connector and ground.

Is there battery voltage?

- YES** –
- Check or replace the strobe control unit
 - Check for open circuit in the Red/green wire
- NO** – Replace the strobe relay (page 28-23).

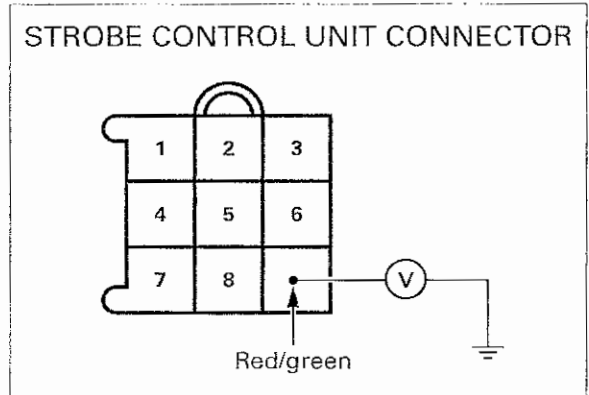

COMPONENT LOCATION PHOTOGRAPHS

1. Left side of fairing (mirror cover removed)

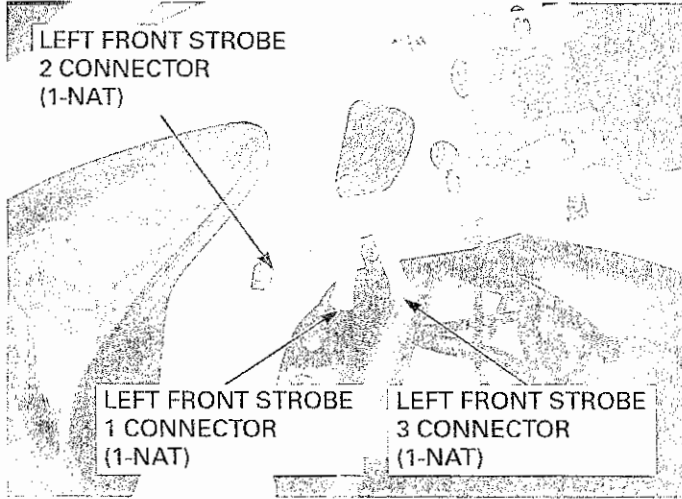

4. Top rear of engine (fuel tank lifted)

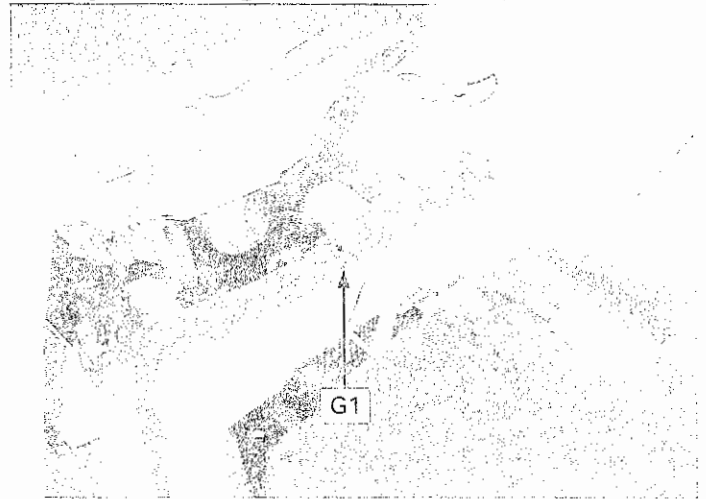

2. Right side of fairing (mirror cover removed)

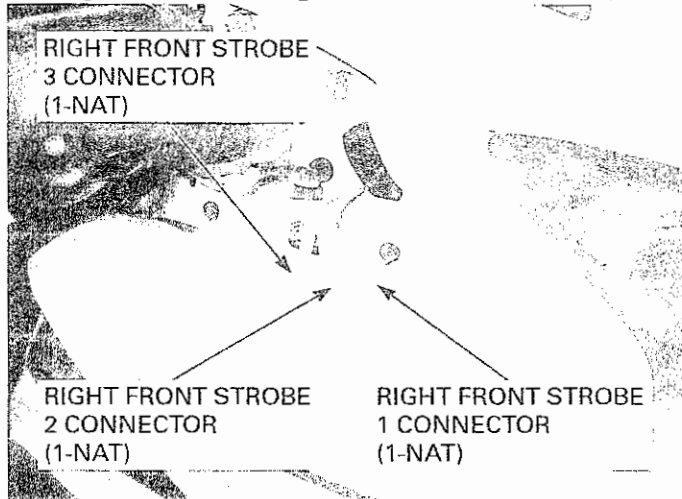

5. Left side of frame (left middle cowl removed)

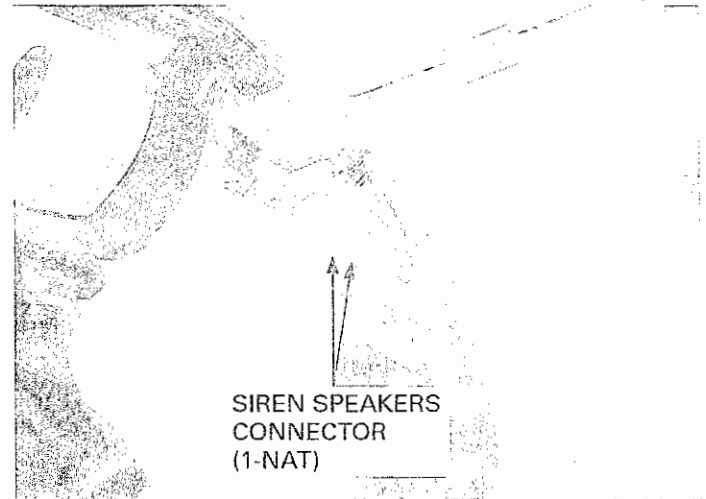

3. Right side of frame (right middle cowl removed)

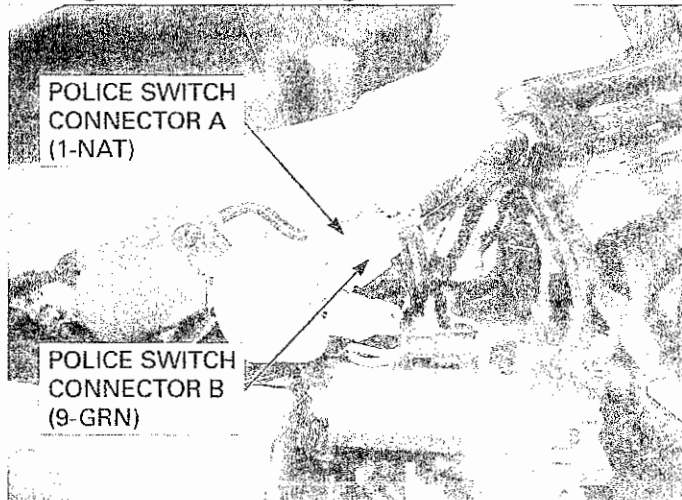

6. Fuses (left side cover removed)

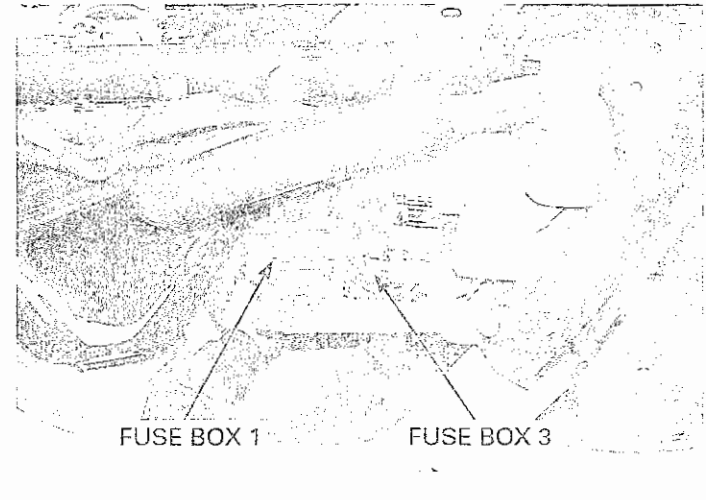

POLICE COMPONENT LOCATION GUIDE

7. Under single seat cowl

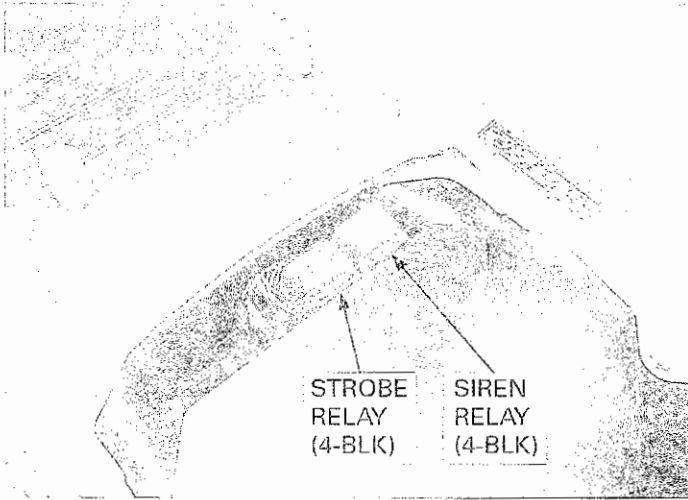

8. Under single seat cowl (amp stay removed)

