

2003 FORD CROWN VICTORIA POLICE AUXILLARY JUNCTION BOX KIT INSTRUCTIONS

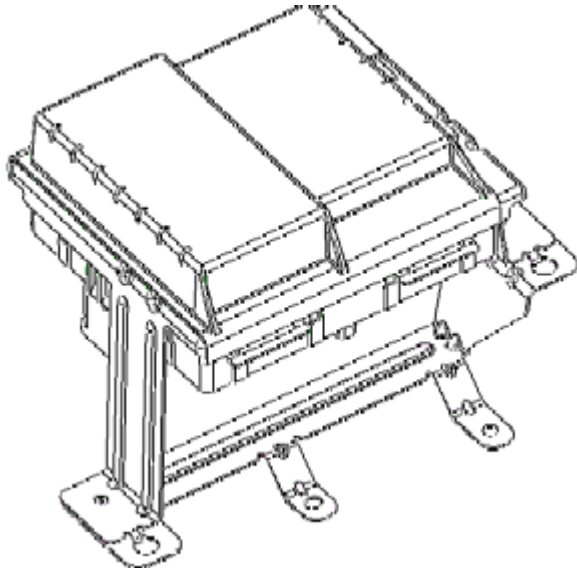

!! WARNING !!

DO NOT SOLDER DIRECTLY TO JUNCTION BOX TERMINALS !!

The printed circuit board technology contained in this device is sensitive to heat. Soldering directly to terminals in this junction box may cause internal solder reflow, which can cause loss of conductivity and failure of vehicle and accessory functions.

The use of pigtails provided with the police package is recommended to maintain the integrity of the electrical components.

!! CAUTION !!

It is important that the current drawn from each police accessory circuit does not exceed 70% of the rated fuse / relay for that circuit.

Each junction box kit should contain the following parts:

Description	Front Qty	Rear Qty
Front Junction Box Subassembly	1	0
Junction Box	0	1
Front Bracket	1	0
Rear Bracket	0	1
Accessory pigtail assembly	0	1
CB pocket pigtail assembly	1	0
CC pocket pigtail assembly	1	0
CD pocket pigtail assembly	1	1
Jumper harness assembly	0	1
JB cover	1	1
JB mounting screw	0	2
Sheet metal screw	2	3

Front Junction Box Subassembly Instructions

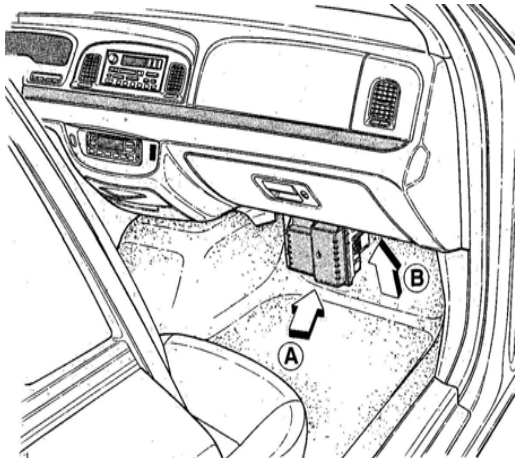

1. Splice police accessories to desired pigtail circuits. See schematic on page 3 for circuit details.
WARNING !! DO NOT SOLDER DIRECTLY TO JUNCTION BOX TERMINALS !!
2. Protect and seal all unused pigtail circuits with either individual heat shrink, other permanent protection, or remove wire from cavity. These circuits will have power running to them once the JB is connected to the main IP harness. Attach accessory connectors to specified junction box cavity.
3. Locate main IP harness tie strapped underneath glove box on passenger side as shown in view B. Cut tie strap to release harness. Attach harness connectors to JB by placing the red connector into pocket C/P, blue connector into pocket C/F, green connector into pocket C/G, and grey connector into pocket C/H. Test all police accessories for functionality.
4. Install front JB subassembly into vehicle. Use locator tabs on front bracket to align with holes on base bracket as shown in view A. Use two sheet metal screws to secure junction box assembly to base bracket. Apply torque of 1.5 Nm +/- 0.2 Nm.
5. Insert top cover hinge tabs at top of front bracket and close until cover latch snaps into bottom edge of bracket.

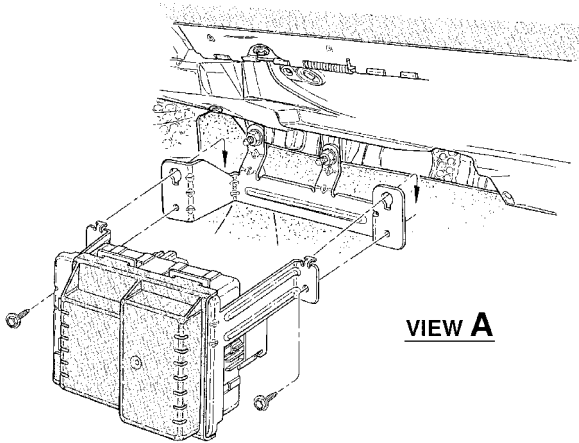

VIEW A

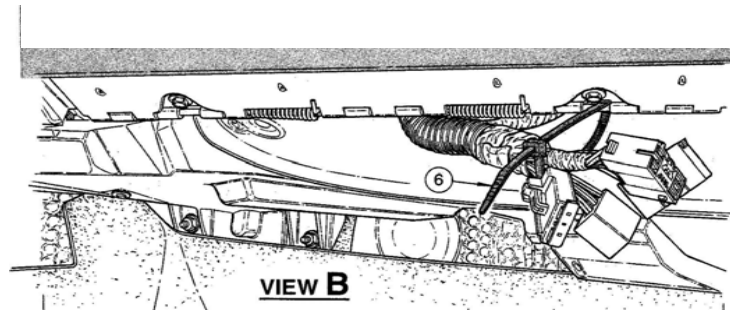

VIEW B

Note: Input circuits CF7, CF8, and CF14 (see schematic on page 3) are pigtails taped back into the IP harness. These pigtails are to be pulled out of the IP harness and is up to the police outfitter to control the three relays to their liking.

Junction Box Schematic

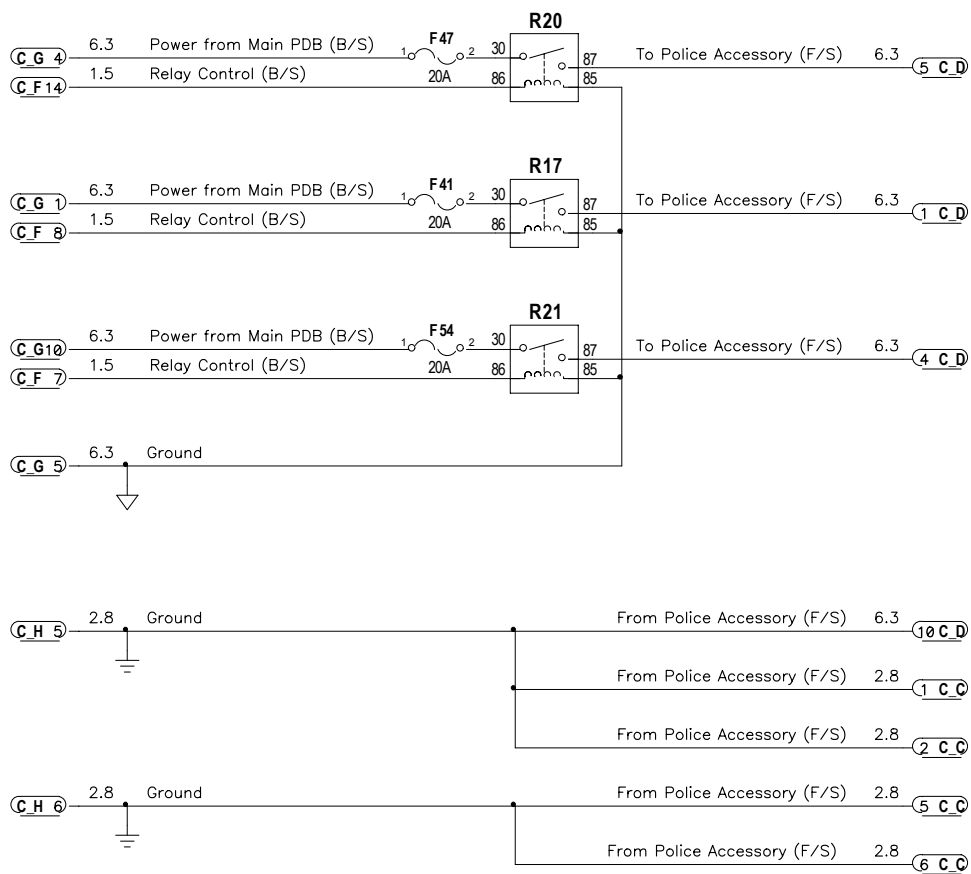
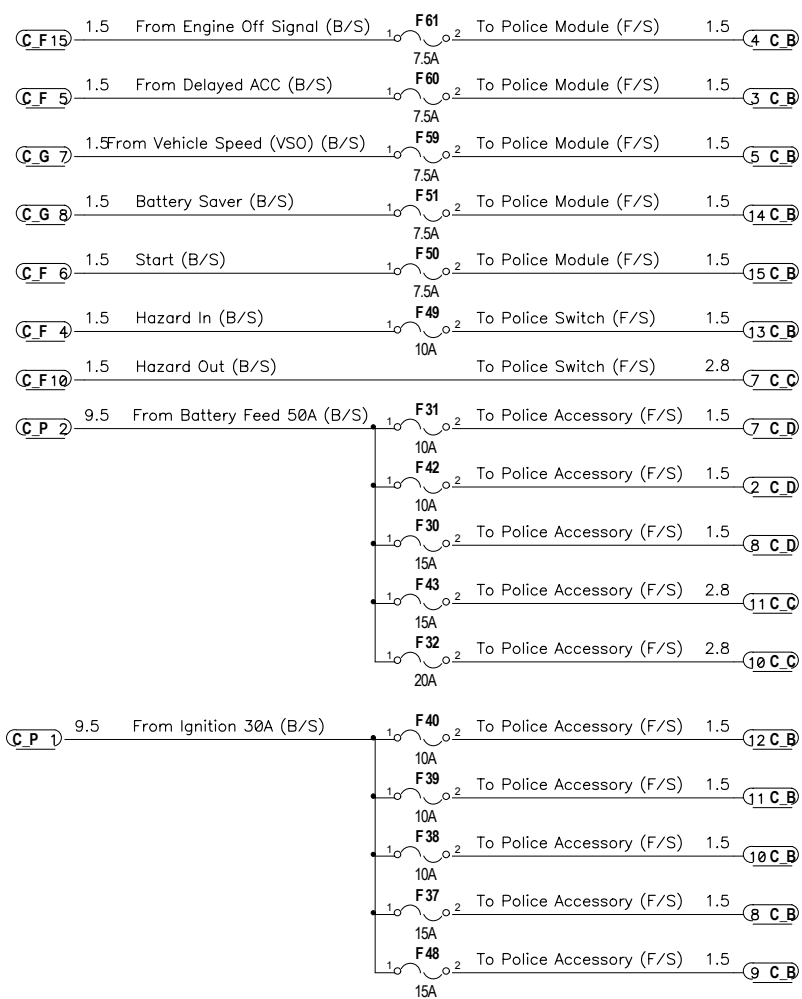

Rear Junction Box Kit Instructions

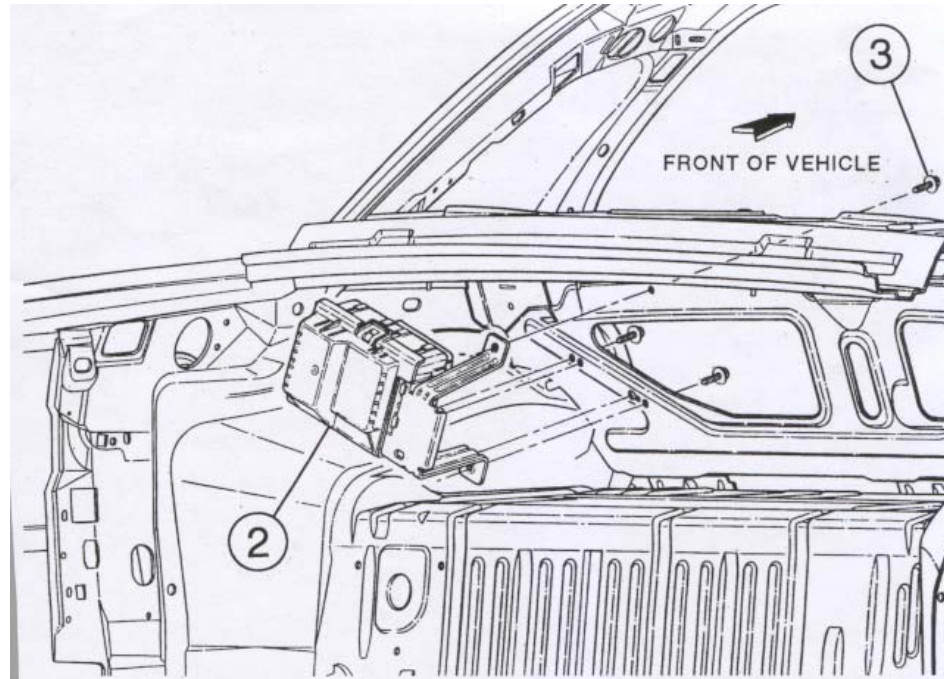

THIS OPERATION WILL REQUIRE THE REMOVAL OF THE REAR SEAT, AND DEADENER BEFORE INSTALLATION.

1. From inside vehicle, remove rear seat bench. Then remove seat back. Peel away deadener to expose sheet metal.
2. Enter vehicle at left rear door, and be seated so legs are in door opening. Reach through rear screen, grab assembly and use mounting tabs on bracket feet to hang assembly on seat screen (insert key hole tab first).
3. Drive three sheet metal screws (item 1) through the screen and into the feet of the three legs of rear assembly bracket.
4. Splice police accessories to desired pigtail circuits. See schematic on page 3 for circuit details. **WARNING !! DO NOT SOLDER DIRECTLY TO JUNCTION BOX TERMINALS !!!**
5. Protect and seal all unused pigtail circuits with either individual heat shrink, other permanent protection, or remove wire from cavity. These circuits will have power running to them once the JB is connected to the main body harness. Attach accessory connectors to specified junction box cavity.
6. Attach junction box jumper harness into main body harness (2 places).

Police Accessory Pigtail Connectors

Note: All connector views are shown in face view. See page 6 for circuit detail.

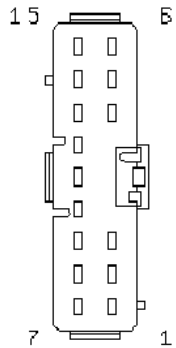

**CB Cavity Pigtail
Connector (black)
Front Police JB Only**

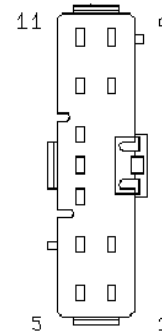

**CC Cavity Pigtail
Connector (green)
Front Police JB Only**

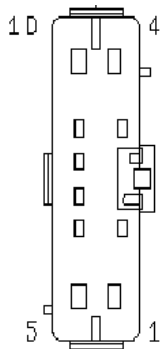

**CD Cavity Pigtail
Connector (black)
Front and Rear Police JB**

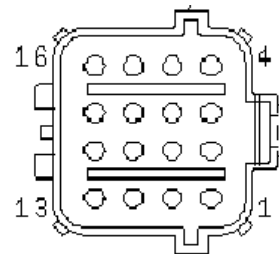

**AA Accessory Harness
Pigtail Connector (grey)
Rear Police JB Only**

CB CAVITY PIGTAIL			
Cavity Number	Wire Color	Wire Size	Max Current (A)
3	White w/ red stripe	20	5.25
4	Light blue w/ orange stripe	20	5.25
5	Red w/ white stripe	20	5.25
8	Brown w/ light blue stripe	20	10.5
9	Purple w/ white stripe	20	10.5
10	White w/ light green stripe	20	7
11	Black w/ orange stripe	20	7
12	Black w/ yellow stripe	20	7
13	Yellow w/ light blue stripe	20	7
14	Light blue w/ yellow stripe	20	5.25
15	Light green w/ black stripe	20	5.25

CC CAVITY PIGTAIL			
Cavity Number	Wire Color	Wire Size	Max Current (A)
1	Tan w/ red stripe	14	10
2	Orange w/ light green stripe	14	10
5	Dark blue with light green stripe	14	20
6	White	14	20
7	Yellow w/ red stripe	18	7
10	Light blue	16	14
11	Purple	18	10.5

CD CAVITY PIGTAIL			
Cavity Number	Wire Color	Wire Size	Max Current (A)
1	Orange w/ red stripe	14	14
2	Dark Blue	20	7
4	Yellow w/ white stripe	14	14
5	Light blue w/ pink stripe	14	14
7	Black w/ yellow stripe	20	7
8	Red w/ orange stripe	20	10.5
10	Yellow w/ red stripe	14	25

AA CAVITY PIGTAIL			
Cavity Number	Wire Color	Wire Size	Max Current (A)
1	Dark green w/ light green stripe	20	7
2	Pink w/ yellow stripe	20	7
3	Orange	20	7
4	Light blue w/ yellow stripe	20	10.5
5	Grey	20	10.5
6	White w/ orange stripe	20	5.25
7	Dark green	20	5.25
8	Pink w/ light blue stripe	20	7
9	Yellow w/ red stripe	20	5.25
10	White	20	5.25
11	Dark Blue	18	10.5
12	Light blue	16	14
13	Light green	18	7
14	Black	14	20
15	Black	14	20
16	Black	14	20